

## 1.0 Microprocessor Access

As seen on the microprocessor bus there are eight I/O addresses, selected by RS[2:0]. Two indirect schemes are used to access all of the internal registers and arrays through these eight primary I/O addresses.

The first scheme is standard VGA, and operates when RS[2] = 0. Of the four I/O addresses then available with RS[1:0], only one address directly accesses a register, the Pixel Mask. The other three addresses are used to indirectly access the three 256x8 palettes.

The second scheme is an indexed scheme and is used to access all of the remaining registers including the cursor array. This scheme operates when RS[2] = 1. Of the four I/O addresses then available using RS[1:0], two are used to load an index register (Low and High). The third address is used to write or read the register or array position pointed to by the index register. The fourth address is used to directly access a register which controls whether the index register automatically increments following an indexed register access.

The eight I/O addresses selected by RS[2:0] are listed in Table 1 below:

Table 1. I/O Addresses

RS[2:0]	Register
000	Palette Address (Write Mode)
001	Palette Data
010	Pixel Mask
011	Palette Address (Read Mode)
100	Index Low
101	Index High
110	Index Data (Indexed Registers)
111	Index Control

### 1.1 VGA Access

#### 1.1.1 Palette

Internally the three 256x8 palettes are accessed by the microprocessor as a single 256x24 palette, with all 24 bits written or read in one operation.

A single Palette Address register points to 1 of 256 locations for writing or reading the 24 bits. Two different Register Select addresses are used to access the Palette Address register.

A write to RS[2:0] = 000 (Palette Address Write Mode) initializes the palette logic for write operations. Subsequent writes to Palette Data (RS[2:0] = 001) will load internal palette color registers and cause these register contents to be written into the palettes.

A write to RS[2:0] = 011 (Palette Address Read Mode) initializes the palette logic for read operations. Data from the palettes will be loaded into internal palette color registers. Subsequent reads from Palette Data (RS[2:0] = 001) will read these palette color registers.

Every three accesses of Palette Data (RS[2:0] = 001) will cause the Palette Address register to be incremented. An increment past 0xff will "wrap around" to 0x00.

A read from either Palette Address (Write Mode) or Palette Address (Read Mode) will read the Palette Address register. The same register is used for writing and reading, thus, changing modes destroys the contents of the previous mode's palette address. For example, if some reads are performed and then Palette Address (Write mode) is written, the read address will be lost and a read of either Palette Address (Write Mode) or Palette Address (Read Mode) will produce the same result: the address that was written into Palette Address (Write Mode).

#### 1.1.2 Palette Write

Palette writes must be initialized by writing the Palette Address (Write Mode) register. This provides a starting address for writes and initializes the internal circuitry for palette write operations.

Palette writes are then performed by writing to Palette Data in a red, green, blue... sequence. These writes will load internal palette data registers in sequence. Immediately following every third write, an internal write will be triggered to the palette of the 24 bits contained in the internal palette data registers, at the address contained in the Palette Address register.

Immediately following the internal palette write triggered by the third write to Palette Data, the Palette Address register will be incremented. Thus, continuous writes to Palette Data will load the palette, stepping through the palette addresses in ascending order.

### 1.1.3 Palette Read

Palette reads must be initialized by writing the Palette Address (Read Mode) register. This provides a starting address for reads and initializes the internal circuitry for palette read operations.

Immediately following the writing of Palette Address (Read Mode), a read of the palette will be performed at the address just written. Internal palette data registers are loaded with the read data, and the Palette Address register is incremented.

Palette reads are then performed by reading from Palette Data. Red, green, blue... data from the preloaded internal registers will be presented in sequence. Immediately following every third read, an internal read of the palette to the 24 bits contained in the internal registers will be performed at the address contained in the Palette Address register.

Immediately following the internal palette read triggered by the third read of Palette Data, the Palette Address register will be incremented. Thus, continuous reads of Palette Data will read the palette, stepping through the palette addresses in ascending order.

### 1.1.4 6/8 Bit Palette Access

The original VGA had 6-bit DACs and 6-bit palette entries, and the low order 6 bits from/to the microprocessor port were written/read into the palette.

For the RGB525, the DACs and palette entries are 8 bits. For non-VGA emulation all 8 bits are used. To emulate 6-bit VGA operation the upper 6 bits of the palette hold the VGA 6-bit color and the two low order bits are set to 00. The COL RES bit (color resolution) of the Miscellaneous Control 2 register determines if the access is 6-bit or 8-bit.

The reset condition is to emulate VGA using the 6 low order microprocessor data bits. COL RES is set to 6 bits. In this mode, for writing, microprocessor bits [7:6] are discarded, bits [5:0] are shifted to bits [7:2], and bits [1:0] are set to 00 before being written into the internal data registers. For reading, the internal data register bits [7:2] are shifted to bits [5:0], and bits [7:6] are set to 00 before being presented on the microprocessor data signals.

If COL RES is set to 8 bits then all 8 bits from/to the microprocessor will be written to and read from the color palette registers.

Note that the 6-to-8 bit translation is only done between the microprocessor port and the internal data registers. Internally, on writes, all 8 bits of the internal registers are written to the palette, and on reads, the internal registers retain all 8 bits read from the palette. Thus, if the palette is loaded with 8-bit values with COL RES set to 8 bits, and then the palette is read with COL RES set to 6 bits, the internal palette color registers will still be loaded with the 8 bits that were written into the palette. But the data read on the microprocessor data lines will be 6 bits.

### 1.1.5 Palette Clocking

Palette accesses are synchronized internally with the pixel clock. On writes, the pixel values of the previous cycle are held and displayed during the write cycle. Both of these features minimize disturbance of displayed pixels when the palette is accessed (anti-sparkle).

The pixel clock (as selected by the PCLK SEL bits in Miscellaneous Control 2) must be running for palette access to be valid.

The timings for the microprocessor signals are specified in units of pixel clocks. These specifications are derived from the requirement for the pixel clock to be running for palette access, as well as to allow time for the Palette Accesses and Palette Address increments to occur internally following a palette access.

### 1.1.6 Palette Access Status

The original VGA logic had an override for read accesses of the Palette Address (Read Mode) register. Instead of reading the Palette Address register, a value was returned that indicates the status of the last palette access, write or read.

The reset condition of the RGB525 is to return the address value for a read of Palette Address (Read Mode). The VGA logic may be emulated by setting the RADR RFMT bit in Miscellaneous Control 1. This causes the status of the last palette access to be returned.

The value of the status returned is 0x00 if the last write to Palette Address was Write Mode, and 0x03 if the last write to Palette Address was Read Mode.

### 1.1.7 Pixel Mask

The pixel mask is an 8-bit register addressed with RS[2:0] = 010. It can be accessed at any time without disturbing a palette write or read sequence.

Accesses to the pixel mask are asynchronous to the pixel clock. Temporary color disturbances can be expected if the mask is changed while displaying pixels through the palette.

## 1.2 Indexed Access

The cursor array and a number of control registers are addressed with an internal 11-bit index register. The microprocessor accesses this as Index High (RS[2:0] = 101) and Index Low (RS[2:0] = 100).

A write or read to Index Data (RS[2:0] = 110) actually writes or reads the register/cursor array location addressed by the Index register.

Following a write or read of Index Data, the index register will increment if the INDX CNTL bit is set. The Index Control register (RS[2:0] = 111) contains this bit. To allow for future expansion, wraparound from 0x07ff to 0x0000 is **not** supported.

In general, access of Index Low, Index High, Index Control, or any of the Indexed registers is independent of the palette access and will not disturb a palette write or read sequence. However, as described above the PADR RFMT bit in Miscellaneous Control 1, the COL RES bit in Miscellaneous Control 2, and the 6BIT ACC bit in Palette Control all affect palette access.

Also, as described above, the pixel clock must be running for valid access of the palette, and the pixel clock is affected by a number of indexed registers.

### 1.2.1 Cursor Array

In general, the indexed registers may be written or read at any time, using the address held in Index High and Index Low. This address may be set by writing to Index High or Index Low, or the value may result from the auto-increment action of a previous access.

However, as described in 8.2.3, "Cursor Array Reads," on page 17, to access the cursor array a write to Index High or Index Low must be performed first. That is, the cursor array cannot be accessed by auto-increment from address 0x00ff to 0x0100.

Also, as with the palette, the pixel clock must be running to access the cursor array.

## 2.0 Clocking

### 2.1 PLL Inputs

#### 2.1.1 REFCLK

The REFCLK input is a reference clock that the PLL uses in conjunction with programming registers to produce a wide variety of frequencies. In general, REFCLK can be any frequency from 2 MHz through 100 MHz. When the "direct programming" method is used (see below), the REFCLK must lie on a 2 MHz boundary in the range of 4 MHz through 62 MHz (4 MHz, 6 MHz, 8 MHz,... 62 MHz).

#### 2.1.2 EXTCLK

An alternate source of the reference frequency to the PLL is the EXTCLK input. This is selected with the REF SRC bit of the PLL Control 1 register.

### 2.2 PLL Outputs

The PLL is used internally as the pixel clock. The maximum allowed generated frequency is 170/220/250 MHz, dependent on the product version.

The PLL Output is not available directly. However, two divided versions are provided as output signals:

- SCLK
- DDOTCLK

#### 2.2.1 SCLK

SCLK (Serial Clock) is intended for clocking of the serial outputs of the VRAMs to the pixel port inputs. As such, the divide factor is a function of the VRAM pixel port width (64 or 32 bits), and the number of pixels contained in an access. For example, with a VRAM width of 64 and operating at 16 bits-per-pixel, there will be 64/16 = 4 pixels brought in with each VRAM access, and SCLK will operate at 1/4 the frequency of the PLL output.

If the VGA port is selected SCLK will simply be the output of the PLL. Table 3, "SCLK Frequencies," shows all the SCLK frequencies that are produced.

**Table 2. SCLK Frequencies**

BPP	VRAM=32	VRAM=64
4	+ 8	+ 16
8	+ 4	+ 8
15/16	+ 2	+ 4
32	+ 1	+ 2
24 Packed	Invalid	+ (8/3)
VGA	+ 1	

“24 Packed” is a special case. It is only valid with a VRAM width of 64, and it produces 3 SCLKs for every 8 internal pixel clocks as shown in Figure 1.

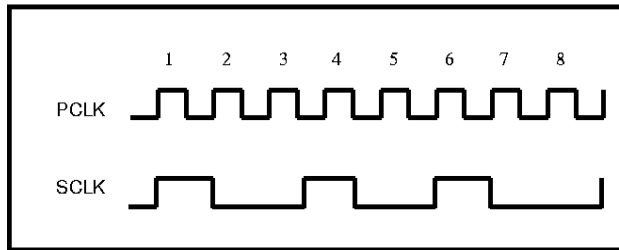

Figure 1. SCLK for 24 BPP Packed

### 2.2.2 DDOTCLK

DDOTCLK (Divided Dot Clock) is simply the PLL output divided by 1, 2, 4, 8 or 16 as determined by the DDOT DIV bits of the Miscellaneous Clock Control register.

Note that the maximum supported output frequency of DDOTCLK is 100 MHz, so some values of the DDOT DIV bits will become illegal when the PLL is programmed to operate beyond this frequency.

When a pixel format of 24 BPP Packed is selected, the SCLK output may be driven on DDOTCLK instead of the divided PLL output, under control of the B24P DDOT bit of the Miscellaneous Clock Control register.

Either DDOTCLK or SCLK, or both, are intended for use as the video clock for the graphics controller(s). For example, DDOTCLK could drive a VGA controller, and SCLK could drive a GUI accelerator. If the VGA controller and the GUI accelerator are combined in a single chip, then perhaps SCLK is used and DDOTCLK is not used, or vice versa. The DDOT DSAB and SCLK DSAB bits of the Miscellaneous Clock Control register can be used to 3-state an unused clock output.

## 2.3 Load Clock

The LCLK input (Load Clock) is used to latch up all incoming pixel data and video controls. The maximum frequency of this input is 100 MHz.

## 2.4 Pixel Clock (Dot Clock)

The pixel clock, or dot clock, is the internal clock used to clock pixel data up through the DACs. It is also required to be running to access the palette and the cursor. The maximum frequency of this clock is 170/220/250 MHz (depending on the chip version).

There are several sources of the pixel clock, as selected by the PCLK SEL bits in the Miscellaneous Control 2 register:

**LCLK input** This is the reset default. It is intended to be used when the VGA port is selected as the pixel source.

**PLL output** This is intended to be used when the VRAM pixel port is selected as the pixel source. It provides the highest pixel clock operation.

**EXTCLK input** This is intended for laboratory bringup.

When LCLK is selected as the pixel clock all internal pixel operations are synchronous with LCLK. If the pixel clock is sourced by the PLL output or EXTCLK, then the incoming pixels and video controls are expected to be derived from SCLK. After latching the signals with LCLK, the signals are clocked with an internal SCLK, and then clocked with the internal pixel clock. LCLK must maintain a specified relationship to SCLK to achieve the internal transfer of the clocking from LCLK to SCLK.

## 2.5 PLL Setup and Reset

The PLL is enabled for running at a programmed frequency by setting the REF DIV COUNT, VCO DIV COUNT, and DF bits (as described in the following sections), and then setting the PLL ENAB bit of the Miscellaneous Clock Control register.

When the PLL ENAB bit is 0 (off), the PLL will continue to run but the frequency will not be determined by programming values. The PLL will drive to its lowest frequency of operation, in the range of 5 KHz to 250 KHz.

The pixel clock frequency is determined by the DF programming bits. When DF = 00, the pixel clock is equal to the PLL clock divided by 4 (1.25 KHz to 62.5 KHz).

When DF = 01 the pixel clock equals the PLL clock divided by 2 (2.25 KHz to 125 KHz), and when DF = 10 or 11, the pixel clocks equals the PLL clock (5 KHz to 250 KHz.)

Following a reset, the PLL ENAB bit is off and the DF bits of all programming registers are set to 00, so the pixel clock will be PLL clock/4 = 1.25 KHz to 64.25 KHz.) The PORT SEL bit of Miscellaneous Control 2 register will be 0 (VGA port), which will cause the SCLK output to be the same as the pixel clock (1.25 KHz to 64.25 KHz.) The DDOT DIV bits of the Miscellaneous Clock Control register will be zero, which will cause DDOT-CLK to also be the same frequency as the pixel clock.

## 2.6 PLL Programming

The PLL is programmed with three values:

**REF DIV COUNT (Reference Divide Count)** This number provides a count value for dividing down the incoming REFCLK. It must be between 2 and 31. Operation of the PLL is indeterminate if this number is 0 or 1.

**VCO DIV COUNT (VCO Divide Count)** This number provides a count value for the divider in the PLL feedback loop. The value can range from 0 through 63. Internally, 65 is added to VCO DIV COUNT, so that the PLL feedback divider value ranges from 65 through 128.

**DF (Desired Frequency)** These are two bits with values of 00, 01, 10, and 11. The intent of these bits is to divide the operation of the PLL into four frequency ranges. Following the divide of the REFCLK provided by the REF DIV COUNT there is an additional divide-by-two which is selected or bypassed with the DF bits. Also, the output of the PLL has a divider stage, or postscaler, that is controlled by the DF bits.

Table 3, "PLL Equations," gives the general formulas for programming the PLL. Because of the action of the DF bits there are four equations, one for each DF bit setting.

It is possible to program the PLL with values that generate illegal operating conditions:

1. The reference frequency VRF (Video Reference Frequency), which is internal to the PLL, cannot be less than 1 MHz.
2. The internal VCO (Voltage Controlled Oscillator) cannot exceed the rated speed of the product (170/220/250 MHz).

Table 3, "PLL Equations," gives the equations for calculating the internal VRF. Table 3 also gives the maximum allowable dot clock frequency for each setting of DF. This reflects the action of the VCO postscaler. If the PLL is programmed so that these maximum dot clock frequencies are not exceeded then the maximum VCO frequency will not be exceeded.

**Table 3. PLL Equations**

DF	Dot Clock Frequency	Internal VRF	Maximum Dot Clock (MHz)		
			170	220	250
00	$\frac{\text{FREF} \times (\text{VCO DIV COUNT} + 65)}{(\text{REF DIV COUNT}) \times 8}$	$\frac{\text{FREF}}{(\text{REF DIV COUNT}) \times 2}$	42.5	55.0	62.5
01	$\frac{\text{FREF} \times (\text{VCO DIV COUNT} + 65)}{(\text{REF DIV COUNT}) \times 4}$	$\frac{\text{FREF}}{(\text{REF DIV COUNT}) \times 2}$	85	110	125
10	$\frac{\text{FREF} \times (\text{VCO DIV COUNT} + 65)}{(\text{REF DIV COUNT}) \times 2}$	$\frac{\text{FREF}}{(\text{REF DIV COUNT}) \times 2}$	170	220	250
11	$\frac{\text{FREF} \times (\text{VCO DIV COUNT} + 65)}{\text{REF DIV COUNT}}$	$\frac{\text{FREF}}{\text{REF DIV COUNT}}$	170	220	250

FREF = REFCLK frequency

## 2.7 PLL Frequency Selection

The REF DIV COUNT, VCO DIV COUNT, and DF bits are provided to the PLL in a pair of 8 bit registers. REF DIV COUNT is 5 bits and occupies one register, with the 3 high order bits unused. The 6 VCO DIV COUNT bits occupy the second register, with the two high order bits used by DF.

There are actually 17 registers which can be used to hold these programming values: Fixed PLL Reference Divider and F0 - F15. A pair of registers is selected from this group to provide the PLL programming values. This selection is controlled by the PLL Control 1 and PLL Control 2 registers.

Two different programming styles are supported:

**Direct Programming** In this scheme only the register holding VCO DIV COUNT and DF is altered to change the frequencies. The register for REF DIV COUNT holds a value that is constant for all frequencies. This method is discussed in more detail below.

**M over N** In this scheme both register values are changed to program a new frequency. The name refers to the general PLL concept in which

$$\text{Output frequency} = \text{Input reference} \times (M/N)$$

where VCO DIV COUNT serves as M and REF DIV COUNT serves as N, with modifications to the equation as shown in Table 3, "PLL Equations."

When the direct programming style is used the single REF DIV COUNT is stored in the Fixed PLL Reference Divider register. Up to 16 values of VCO DIV COUNT and DF can be stored in the F0 - F15 registers, allowing 16 preprogrammed pixel clock frequencies.

With the M/N style the Fixed PLL Reference Divider register is not used. The F0 - F15 are reconfigured as 8 pairs of M and N values (M0,N0,M1,N1, ... M7,N7). This allows 8 preprogrammed pixel clock frequencies.

The selection of the programming registers, either 1 of the 16 F0 - F15 registers or 1 of the 8 M/N pairs, is done either externally with the FS[3:0] inputs to the module, or internally with the FS[3:0] bits of PLL Control 2 register. When the M/N style is used FS[3] is ignored.

The programming style and selection source is chosen with the EXT/INT bits of the PLL Control 1 register, as shown in Table 4, "PLL Control 1 EXT/INT Frequency Selection."

**Table 4. PLL Control 1 EXT/INT Frequency Selection**

EXT /INT	Frequency Selection	REF DIV COUNT	VCO DIV COUNT, DF
000	External FS[3:0]	Fixed Reference Divider	F0-F15
001	External FS[2:0]	N0-N7	M0-M7
010	Internal FS[3:0]	Fixed Reference Divider	F0-F15
011	Internal FS[2:0]	N0-N7	M0-M7

**Table 5. Direct Programming Reference Divider Values**

REFCLK (MHz)	Fixed PLL Reference Divider Register Value
4	0x0002
6	0x0003
8	0x0004
10	0x0005
12	0x0006
14	0x0007
16	0x0008
18	0x0009
20	0x000a
22	0x000b
24	0x000c
26	0x000d
28	0x000e
30	0x000f
32	0x0010
34	0x0011
36	0x0012
38	0x0013
40	0x0014
42	0x0015
44	0x0016
46	0x0017
48	0x0018
50	0x0019
52	0x001a
54	0x001b
56	0x001c
58	0x001d
60	0x001e
62	0x001f

## 2.8 Direct Programming

Use the following steps to calculate the values used with direct programming:

1. Look up the REFCLK frequency in Table 5, "Direct Programming Reference Divider Values," and write the given programming value into the Fixed PLL Reference Divider register. If the incoming REFCLK (or EXTCLK) frequency does not appear in this table then the direct programming method cannot be used.
2. Use Table 6, "PLL Direct Programming Equations," to determine the values to write into the F0 - F15 registers. First, pick the row of the table whose frequency range covers the frequency of interest. This will determine the value of the DF bits to write. Next, use the given equation to calculate the value of the VCO DIV BITS. Write these two values together in one of the F0 - F15 registers.

The generated pixel clock frequency is designated in this table as VF, for Video Frequency. Note that within each range the desired VF frequency must lie on a given step value (e.g., with DF = 11 a frequency of 159 MHz is invalid because it does not lie on a 2 MHz step; but either 158 MHz or 160 MHz is valid).

Table 6. PLL Direct Programming Equations

DF	VCO Divide Count	Frequency Range	Step (MHz)
00	$(4 \times VF) - 65$	16.25 - 32 MHz	0.25
01	$(2 \times VF) - 65$	32.5 - 64 MHz	0.5
10	$VF - 65$	65.0 - 128 MHz	1.0
11	$(VF / 2) - 65$	130.0 - 250 MHz	2.0

VF = Desired Video Frequency

## 2.9 M/N Programming

For the "M over N" programming style use Table 3, "PLL Equations," in the following steps:

1. Select values for REF DIV COUNT, VCO DIV COUNT, and DF that generate the desired frequency (or come close enough). Note that the values 0 and 1 are illegal for REF DIV COUNT under all conditions.
2. Calculate the internal reference frequency VRF. Verify that this frequency is not less than 1 MHz.
3. Verify that the dot clock frequency does not exceed the maximum value specified in the table.
4. If conditions 2 and 3 are not met then the selected values cannot be used.

## 2.10 General PLL Programming

The register selection specified with the EXT/INT bits of the PLL Control 1 register does not force the selection of programming style, direct or M/N. For example, there is nothing to prevent an arbitrary value from being written into the Fixed PLL Reference Divider and writing an appropriate value into one of the F0 - F15 registers as calculated with the M/N method. Of course, if multiple "N" values are used and they have to be re-written to the Fixed PLL Reference Divider every time the FS[3:0] value changes, this defeats the purpose of the FS[3:0] selection mechanism.

Likewise, when the 1-of-8 M/N register selection is used there is nothing to prevent the direct programming equations from being used for the values. The same value will wind up being used for all of the "N" values.

Fundamentally the only differences between the two programming styles are these:

1. Direct programming can be used only if the REFCLK frequency falls on a 2 MHz boundary from 4 MHz through 62 MHz.
2. With direct programming, for a given pixel clock frequency there is only one set of programming values. These values are obtained from Table 5, "Direct Programming Reference Divider Values," and Table 6, "PLL Direct Programming Equations." Illegal conditions cannot be generated as long as the correct value from Table 5, "Direct Programming Reference Divider Values," is used.
3. M/N can be used with any REFCLK frequency from 2 MHz through 100 MHz
4. A given pixel clock can be generated with multiple combinations of programming values. Some of these values can produce illegal internal conditions. Table 3, "PLL Equations," is used to calculate the resulting pixel clock and to determine if conditions are violated.

## 2.11 Diagnostic Readback

The read-only registers PLL VCO Divider Input and PLL Reference Divider Input contain the programming values actually used by the PLL. These registers can be used to verify that the desired programming registers are the ones actually selected.



### 3.0 Modes of Operation

Pixel data can come from the VGA port or the VRAM pixel port, as selected by the PORT SEL bit of the Miscellaneous Control 2 register.

If the VRAM pixel port is selected, the pixel format can be 4 BPP (bits per pixel), 8 BPP, 15/16 BPP, 24 BPP Packed, or 32 BPP, selected by the Format bits of the Pixel Format register. Table 7, "Pixel Format Table," on page 14 shows how the input bits are selected as a function of Pixel Format.

VGA data and 4 BPP data are always used to indirectly generate 24 bits of color by indexing into the 256 entry palettes. The Pixel Mask register is used to selectively mask off the index bits as desired.

8 BPP, 15/16 BPP, 24 BPP Packed, and 32 BPP from the VRAM pixel port can either be indirect (through the palettes) or direct (bypassing the palettes).

Each of these formats has an associated control register with bits to select indirect or direct color. Additionally 15/16 BPP and 32 BPP formats allow a bit within the incoming data to dynamically select indirect or direct color.

As with VGA and 4 BPP, the Pixel Mask is used to mask off palette address bits with indirect color access for 8, 15/16, 24 Packed, and 32 BPP.

#### 3.1 Bit Ordering

Bit order is high-to-low. For 8 BPP, the MSB is '7' and the LSB is '0'; for 16 BPP the MSB is '15' and the LSB is '0', and so on.

When the VRAM pixel port is selected the default condition is to access the pixels from low to high. For each LCLK, the first pixel used is at the end with bit PIX[00], and the last pixel used is at the end with bit PIX[63] (bit PIX[31] for VRAM width = 32). For example, for 8 BPP, the first pixel is PIX[07:00], the second pixel is PIX[15:08], and so on.

For a VRAM width of 64, the SWAP WORD bit of the Miscellaneous Control 3 register may be used to swap the access order of the two incoming words. When swapped, PIX[63:32] will be used for the first pixel(s) and PIX[31:00] will be used for the remaining pixel(s). Within the word access is still low-to-high (e.g., PIX[39:32], PIX[47:40]...).

4 BPP is a special case. Within a byte, the default condition is to select first the high nibble (e.g., PIX[07:04]), then the low nibble (PIX[03:00]). The SWAP NIB bit of the Miscellaneous Control 3 register may be used to swap the order the two nibbles are used. This swap is applied to every byte that is read in, and is only active, when set, for 4 BPP.

#### 3.2 VGA Port

VGA uses 8 bits per pixel. When the VGA port is selected only indirect mode is used. The 8 bits are masked with the Pixel Mask register and presented to the red, green, and blue palettes as indices into the 256 entries of each palette. The masked data is used as the same index into each of the three color palettes.

#### 3.3 VRAM Pixel Port

##### 3.3.1 4 BPP

With 4 BPP format 8 pixels (32-bit VRAM width) or 16 pixels (64-bit VRAM width) are obtained for each pixel port data access. As noted above the default access of the two pixels within each byte are high-to-low:

PIX[7:4] = pixel one

PIX[3:0] = pixel two,

but this can be reversed with the SWAP NIB bit of the Miscellaneous Control 3 register.

4 BPP is only used in indirect color mode. The 4 bits are masked with the 4 low order bits [3:0] of the Pixel Mask. The resultant masked 4 bits are then used to index into each of the red, green, and blue palettes.

With 4 BPP the 256 entry palettes are divided into 16 partitions of 16 entries per partition. The upper 4 bits of the Pixel Mask register are ignored. The PARTITION bits of the Palette Control register are used as the upper 4 bits of the palette address to select the desired partition. The 4 masked pixel bits are used to index to 1-of-16 entries within the selected partition.

##### 3.3.2 8 BPP

With 8 BPP format 4 pixels (32 bit VRAM width) or 8 pixels (64 bit VRAM width) are obtained for each pixel port data access.

8 BPP can be indirect or direct, under control of the B8 DCOL bit of the 8 BPP Control register. If indirect, the 8 bits are masked with the Pixel Mask register and

presented to the red, green, and blue palettes as indices into the 256 entries of each palette.

If direct, the 8 bits are presented to the red, green, and blue DACs. Note that since the red, green, and blue colors are identical the displayed image will be monochrome.

### 3.3.3 16 BPP

With 15 BPP or 16 BPP format 2 pixels (32-bit VRAM width) or 4 pixels (64-bit VRAM width) are obtained for each pixel port data access. The 15 or 16 bits are expanded to 24 bits, under control of the 16 BPP Control register.

The 16 BPP Control register provides a number of options for using the 16 BPP format:

1. The incoming pixel can be 15 bits (555 format) or 16 bits (565 format).
2. The color path can be indirect (through the palettes) or direct (bypassing the palettes). Also, with 555 format, the 16th bit can be used to dynamically switch on a pixel-by-pixel basis between indirect and direct color.
3. If indirect color is selected, the addressing of the palettes can be "sparse" (pixel bits used as high order palette address bits) or "contiguous" (pixel bits used as low order palette address bits).
4. If indirect color with contiguous addressing is selected, the palettes can be divided into partitions. The PARTITION bits of the Palette Control register are used to select the partition by filling in the upper palette address bits. With 555 format 8 partitions are available; with 565 format there are 4 partitions.
5. If direct color is used the pixel bits are sent to the DAC high order bits. The low order bits can be zero filled, or the low order bits can be filled with the high order bits of the pixel data. (See description of ZIB/LIN bit below.)

If dynamic bypass is selected the following conditions will apply:

1. The format will be forced to 15 bits (555), with the unused 16th bit now used to control indirect/direct color selection.
2. The indirect color path will be forced to use sparse addressing of the palettes. Partitions cannot be used.

3. The direct color path will force the low order bits to the DACs to be zero filled (ZIB). LIN format cannot be used.
4. The Pixel Mask will mask the pixel data regardless of whether or not the palette is bypassed.

#### 3.3.3.1 555/565 Formats

The 555/565 bit determines if the pixel is 15 bits (5:5:5 format) or 16 bits (5:6:5 format). The format designator, 5:5:5 or 5:6:5, refer to the bit allocations, high-to-low, for red:green:blue.

With 15 BPP the high order bit of each two bytes (PIX[15], PIX[31], PIX[47], PIX[63]) is discarded unless dynamic bypass is specified (B16 DCOL bits = 01). With dynamic bypass, this bit is used for indirect/direct color selection.

As noted above setting the mode to dynamic bypass will force the format to 555 regardless of the setting of the 555/565 bit.

#### 3.3.3.2 Color Path Selection

The B16 DCOL bits are used to select one of:

1. Indirect color always (00).
2. Direct color always (11).
3. Dynamic selection of indirect or direct color (01).

The expansion to 24 bits varies depending on whether the color path is indirect or direct.

**Indirect Color:** The palette addressing can be sparse or contiguous and is controlled by the SPR/CNT bit. With sparse addressing the pixels will address 32 locations each for the red and blue palettes, and 32 locations for green in 555 format or 64 locations for green in 565 format. With the lower address bits set to zeroes the locations accessed will be "scattered" through the palettes, with the intermediate locations unused.

With contiguous addressing the PARTITION bits of the Palette Control register are used for the high order palette address bits, and the access within each palette is contiguous. For 555 format there are 8 partitions and 32 entries within each partition. For 565 format there are 4 partitions. All 64 entries in the green palette are addressed. Only the lower 32 entries of the red and blue palettes are used; the high 32 entries are not used.

For sparse addressing the low order bits are dependent on the ZIB/LIN bit. This bit *must* be set to 0 (ZIB). This will force the low order bits to zeros. If ZIB/LIN is 1 (LIN) then the values of the low order bits presented to the palettes are undefined.

For sparse addressing the low order Pixel Mask bits have no effect.

For contiguous addressing the high order bits are always supplied by the PARTITION bits and the high order Pixel Mask bits have no effect.

As noted above for dynamic bypass mode the format is forced to 555 mode and addressing is forced to be sparse regardless of the setting of the SPR/CNT bit.

**Direct Color:** To expand the 5 or 6 bits of color from the pixel data to 8 bits, the ZIB/LIN bit of the 16 BPP Control register specifies the generation of the low order 3 or 2 bits. If ZIB (Zero Intensity Black), the low order bits are made 0. If LIN (Linear), the low order bits are made equal to the high order bits. This causes the 5 or 6 bits to expand to 8 bits in a linear fashion, with both zero scale and full scale values used. With Zero Intensity Black, full scale cannot be achieved.

As noted above for dynamic bypass mode the format is forced to 555 mode and the low order fill is forced as ZIB, regardless of the setting of the ZIB/LIN bit.

### 3.3.3.3 Dynamic Bypass

As described above the selection of “dynamic bypass” mode forces the 555 format and uses the high order bit of the incoming 16-bit pixels as a control bit to select, on a pixel-by-pixel basis, the indirect (color lookup) or direct (lookup bypass) path.

The meaning of this bit depends on the BY16 bit in the 16 BPP Control register. When BY16 = 0 the incoming control bit forces the bypass. That is, when the control bit is 1 the palette is bypassed (direct color), and when 0 the palette is not bypassed (indirect color).

When BY16 = 1 the meaning of the incoming control bit is reversed; it now forces a lookup. That is, when the control bit is 1 the palette is used (color lookup), but when 0 the palette is bypassed (direct color).

### 3.3.4 24 BPP

24 BPP Packed can only be selected when the VRAM width is 64 bits. If 24 BPP Packed format is selected with the Pixel Format register, but the VRAM SIZE bit in the Miscellaneous Control 1 register is set for 32 bits, then the product operation is undefined.

With 24 BPP Packed format each 64-bit pixel port data access contains 2+2/3 pixels. Every 3 consecutive pixel port data accesses (3 × 8 = 24 bytes) contains 8 pixels of 3 bytes each. The assignment of the bytes for each of the

three accesses is shown in Figure 2 on page 12. Each byte contains 8 bits of red, green, or blue color. Color access can be indirect or direct, and is selected with the B24P DCOL bit of the 24 BPP Packed Control register.

For indirect color, the 8 bits of red, green, and blue are each masked by the Pixel mask, and then presented to the red, green, and blue palettes as indices into the 256 entries of each palette.

For direct color, the 8 bits of red, green, and blue are presented to the DACs.

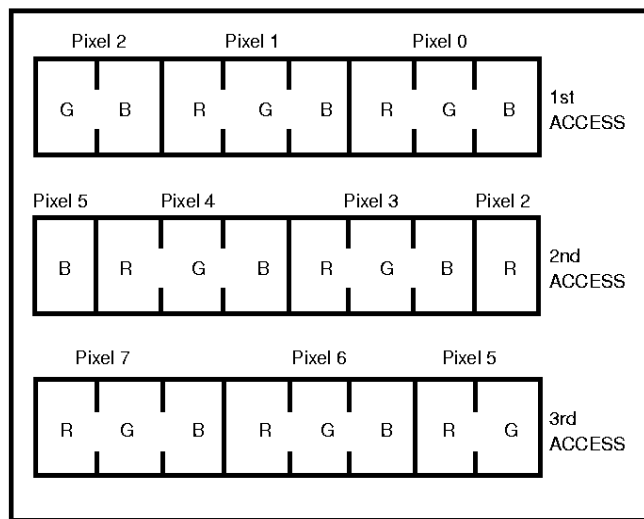

Figure 2. 24 BPP Packed Pixel Input from VRAM

### 3.3.5 32 BPP

With 32 BPP format 1 pixel (32 bit VRAM width) or 2 pixels (64-bit VRAM width) are obtained for each pixel port data access. For each 32 bits accessed, the low three bytes (24 bits) are used for the three colors, with 8 bits each for red, green, and blue.

32 BPP mode is controlled with the 32 BPP Control register. This register has the B32 DCOL bits, which are used to select one of:

1. Indirect color always (00).
2. Direct color always (11).
3. Dynamic selection of indirect or direct color (01).

With indirect color always or direct color always the high order byte is unused. (PIX[31:24] and PIX[63:56])

With dynamic selection (dynamic bypass), the “25th” bit is used as the indirect/direct control bit (PIX[24], PIX[56]) and the remaining bits of the high order byte are unused. (PIX[31:25] and PIX[63:57].) The pixel data in this mode is masked by the Pixel Mask regardless of whether or not the palette is bypassed.

For indirect color, the 8 bits of red, green, and blue are each masked by the Pixel mask, and then presented to the red, green, and blue palettes as indices into the 256 entries of each palette.

For direct color, the 8 bits of red, green, and blue are presented to the DACs.

### 3.3.5.1 Dynamic Bypass

As described above the selection of “dynamic bypass” mode uses the “25th” bit of the incoming 32-bit pixels as a control bit to select, on a pixel-by-pixel basis, the indirect (color lookup) or direct (lookup bypass) path.

The meaning of this bit depends on the BY32 bit in the 32 BPP Control register. When BY32 = 0 the incoming control bit forces the bypass. That is, when the control bit is 1 the palette is bypassed (direct color), and when 0 the palette is not bypassed (indirect color).

When BY32 = 1 the meaning of the incoming control bit is reversed; it now forces a lookup. That is, when the control bit is 1 the palette is used (color lookup), but when 0 the palette is bypassed (direct color).

## 3.4 6 Bit Linear Palette Output

The 6BIT LIN (6 bit linear) bit of the Palette Control register affects the format of the color data read from the palettes and presented to the DACs in indirect color mode. It only has effect when the color resolution is set to 6 bits with the COL RES bit of the Miscellaneous Control 2 register and DCOL CNTL is set to indirect color.

If the palettes contain data with the two low order bits set to 00 (which will be the case when the palettes are loaded with COL RES set to 6 bits), without special processing the data values presented to the DACs will range from 0x00 through 0xfd. The maximum output of the DACs will be approximately 1.5% less than full scale (0xff). This will occur when 6BIT LIN is set to 1.

When 6BIT LIN is set to 0 (the default), then the outputs of the palettes will be modified to allow the DACs to reach full scale output. The modification consists of discarding the two low order bits from the palettes, and

substituting the two high order bits for the two low order bits presented to the DACs. (i.e., the palette bits presented to a DAC will be bits 7 6 5 4 3 2 7 6).

With this bit substitution there will be a “linear” mapping of the palette data range (0x00 – 0xfd) to the DAC data range (0x00 – 0xff), and the DACs will operate over their full range.

If COL RES = 1 (8-bit color resolution) the palette outputs are presented to the DACs unchanged, and 6BIT LIN has no effect. The DACs will operate over the 8-bit range from completely off to full scale on.

Palette linear output is intended for emulation of the VGA 6-bit DACs in which the palette is loaded with 6-bit colors in the 6 high-order bits by setting COL RES to 6-bits. However, regardless of how the palette was loaded or what the pixel format is (VGA, 4, 8, 15/16, 24, 32 BPP), if enabled (DCOL = indirect, COL RES = 6 bit, 6BIT LIN = 0) the palette outputs will be affected as discussed above.

In summary, with the default conditions for VGA mode (indirect color, 6-bit color resolution, 6BIT LIN = 0), there will be a linear mapping of the 6-bit VGA palette data to the DACs, and the DACs will operate over their full range. The mapping can be turned off by setting 6BIT LIN to 1, in which case the 8 bits from the palettes are presented to the DACs unmodified. With 00 in the two low order bits of the palettes the DACs will not reach full scale output.

With 8-bit color resolution (indirect color), or with direct color, the setting of 6BIT LIN has no effect.

## 3.5 Pixel Format Table

Table 7 shows the bit assignments of the pixel data port for each supported pixel format. Prefixes A - P identify individual pixels, and numbers 0 - 7 identify the bit within the pixel. For 4 bit pixels, this information is the data seen by the three color palettes. For 8 bit pixels, it is the data seen by the three color palettes in indirect color mode, and it is the data seen by the three DACs in direct color mode. The suffixes (blu, grn, red) identify the data seen by each of the color palettes (indirect mode) or each of the DACs (direct mode) for 16, 24, and 32 bit pixels.

Table 7. Pixel Format Table

Pixel Port Bit	4 BPP <sup>1</sup>		8 BPP	15/16 BPP <sup>2,3</sup>				24 BPP Packed			32 BPP
	SWAP NIB=0	SWAP NIB=1		555 SPARSE or Direct Color	555 CONTIG	565 SPARSE or Direct Color	565 CONTIG	1st Access	2nd Access	3rd Access	
0	B0	A0	A0	A3BLU	A0BLU	A3BLU	A0BLU	A0BLU	C0RED	F0GRN	A0BLU
1	B1	A1	A1	A4BLU	A1BLU	A4BLU	A1BLU	A1BLU	C1RED	F1GRN	A1BLU
2	B2	A2	A2	A5BLU	A2BLU	A5BLU	A2BLU	A2BLU	C2RED	F2GRN	A2BLU
3	B3	A3	A3	A6BLU	A3BLU	A6BLU	A3BLU	A3BLU	C3RED	F3GRN	A3BLU
4	A0	B0	A4	A7BLU	A4BLU	A7BLU	A4BLU	A4BLU	C4RED	F4GRN	A4BLU
5	A1	B1	A5	A3GRN	A0GRN	A2GRN	A0GRN	A5BLU	C5RED	F5GRN	A5BLU
6	A2	B2	A6	A4GRN	A1GRN	A3GRN	A1GRN	A6BLU	C6RED	F6GRN	A6BLU
7	A3	B3	A7	A5GRN	A2GRN	A4GRN	A2GRN	A7BLU	C7RED	F7GRN	A7BLU
8	D0	C0	B0	A6GRN	A3GRN	A5GRN	A3GRN	A0GRN	D0BLU	F0RED	A0GRN
9	D1	C1	B1	A7GRN	A4GRN	A6GRN	A4GRN	A1GRN	D1BLU	F1RED	A1GRN
10	D2	C2	B2	A3RED	A0RED	A7GRN	A5GRN	A2GRN	D2BLU	F2RED	A2GRN
11	D3	C3	B3	A4RED	A1RED	A3RED	A0RED	A3GRN	D3BLU	F3RED	A3GRN
12	C0	D0	B4	A5RED	A2RED	A4RED	A1RED	A4GRN	D4BLU	F4RED	A4GRN
13	C1	D1	B5	A6RED	A3RED	A5RED	A2RED	A5GRN	D5BLU	F5RED	A5GRN
14	C2	D2	B6	A7RED	A4RED	A6RED	A3RED	A6GRN	D6BLU	F6RED	A6GRN
15	C3	D3	B7	(NOTE 4)	UNUSED	A7RED	A4RED	A7GRN	D7BLU	F7RED	A7GRN
16	F0	E0	C0	B3BLU	B0BLU	B3BLU	B0BLU	A0RED	D0GRN	G0BLU	A0RED
17	F1	E1	C1	B4BLU	B1BLU	B4BLU	B1BLU	A1RED	D1GRN	G1BLU	A1RED
18	F2	E2	C2	B5BLU	B2BLU	B5BLU	B2BLU	A2RED	D2GRN	G2BLU	A2RED
19	F3	E3	C3	B6BLU	B3BLU	B6BLU	B3BLU	A3RED	D3GRN	G3BLU	A3RED
20	E0	F0	C4	B7BLU	B4BLU	B7BLU	B4BLU	A4RED	D4GRN	G4BLU	A4RED
21	E1	F1	C5	B3GRN	B0GRN	B2GRN	B0GRN	A5RED	D5GRN	G5BLU	A5RED
22	E2	F2	C6	B4GRN	B1GRN	B3GRN	B1GRN	A6RED	D6GRN	G6BLU	A6RED
23	E3	F3	C7	B5GRN	B2GRN	B4GRN	B2GRN	A7RED	D7GRN	G7BLU	A7RED
24	H0	G0	D0	B6GRN	B3GRN	B5GRN	B3GRN	B0BLU	D0RED	G0GRN	(NOTE 4)
25	H1	G1	D1	B7GRN	B4GRN	B6GRN	B4GRN	B1BLU	D1RED	G1GRN	UNUSED
26	H2	G2	D2	B3RED	B0RED	B7GRN	B5GRN	B2BLU	D2RED	G2GRN	UNUSED
27	H3	G3	D3	B4RED	B1RED	B3RED	B0RED	B3BLU	D3RED	G3GRN	UNUSED
28	G0	H0	D4	B5RED	B2RED	B4RED	B1RED	B4BLU	D4RED	G4GRN	UNUSED
29	G1	H1	D5	B6RED	B3RED	B5RED	B2RED	B5BLU	D5RED	G5GRN	UNUSED
30	G2	H2	D6	B7RED	B4RED	B6RED	B3RED	B6BLU	D6RED	G6GRN	UNUSED
31	G3	H3	D7	(NOTE 4)	UNUSED	B7RED	B4RED	B7BLU	D7RED	G7GRN	UNUSED
32	J0	I0	E0	C3BLU	C0RED	C3BLU	C0BLU	B0GRN	E0BLU	G0RED	B0BLU
33	J1	I1	E1	C4BLU	C1BLU	C4BLU	C1BLU	B1GRN	E1BLU	G1RED	B1BLU
34	J2	I2	E2	C5BLU	C2BLU	C5BLU	C2BLU	B2GRN	E2BLU	G2RED	B2BLU
35	J3	I3	E3	C6BLU	C3BLU	C6BLU	C3BLU	B3GRN	E3BLU	G3RED	B3BLU
36	I0	J0	E4	C7BLU	C4BLU	C7BLU	C4BLU	B4GRN	E4BLU	G4RED	B4BLU
37	I1	J1	E5	C3GRN	C0GRN	C2GRN	C0GRN	B5GRN	E5BLU	G5RED	B5BLU
38	I2	J2	E6	C4GRN	C1GRN	C3GRN	C1GRN	B6GRN	E6BLU	G6RED	B6BLU
39	I3	J3	E7	C5GRN	C2GRN	C4GRN	C2GRN	B7GRN	E7BLU	G7RED	B7BLU
40	L0	K0	F0	C6GRN	C3GRN	C5GRN	C3GRN	B0RED	E0GRN	H0BLU	B0GRN
41	L1	K1	F1	C7GRN	C4GRN	C6GRN	C4GRN	B1RED	E1GRN	H1BLU	B1GRN
42	L2	K2	F2	C3RED	C0RED	C7GRN	C5GRN	B2RED	E2GRN	H2BLU	B2GRN
43	L3	K3	F3	C4RED	C1RED	C3RED	C0RED	B3RED	E3GRN	H3BLU	B3GRN
44	K0	L0	F4	C5RED	C2RED	C4RED	C1RED	B4RED	E4GRN	H4BLU	B4GRN
45	K1	L1	F5	C6RED	C3RED	C5RED	C2RED	B5RED	E5GRN	H5BLU	B5GRN
46	K2	L2	F6	C7RED	C4RED	C6RED	C3RED	B6RED	E6GRN	H6BLU	B6GRN
47	K3	L3	F7	(NOTE 4)	UNUSED	C7RED	C4RED	B7RED	E7GRN	H7BLU	B7GRN
48	N0	M0	G0	D3BLU	D0BLU	D3BLU	D0BLU	C0BLU	E0RED	H0GRN	B0RED
49	N1	M1	G1	D4BLU	D1BLU	D4BLU	D1BLU	C1BLU	E1RED	H1GRN	B1RED
50	N2	M2	G2	D5BLU	D2BLU	D5BLU	D2BLU	C2BLU	E2RED	H2GRN	B2RED
51	N3	M3	G3	D6BLU	D3BLU	D6BLU	D3BLU	C3BLU	E3RED	H3GRN	B3RED
52	M0	N0	G4	D7BLU	D4BLU	D7BLU	D4BLU	C4BLU	E4RED	H4GRN	B4RED
53	M1	N1	G5	D3GRN	D0GRN	D2GRN	D0GRN	C5BLU	E5RED	H5GRN	B5RED
54	M2	N2	G6	D4GRN	D1GRN	D3GRN	D1GRN	C6BLU	E6RED	H6GRN	B6RED
55	M3	N3	G7	D5GRN	D2GRN	D4GRN	D2GRN	C7BLU	E7RED	H7GRN	B7RED
56	P0	O0	H0	D6GRN	D3GRN	D5GRN	D3GRN	C0GRN	F0BLU	H0RED	(NOTE 4)
57	P1	O1	H1	D7GRN	D4GRN	D6GRN	D4GRN	C1GRN	F1BLU	H1RED	UNUSED
58	P2	O2	H2	D3RED	D0RED	D7GRN	D5GRN	C2GRN	F2BLU	H2RED	UNUSED
59	P3	O3	H3	D4RED	D1RED	D3RED	D0RED	C3GRN	F3BLU	H3RED	UNUSED
60	O0	P0	H4	D5RED	D2RED	D4RED	D1RED	C4GRN	F4BLU	H4RED	UNUSED
61	O1	P1	H5	D6RED	D3RED	D5RED	D2RED	C5GRN	F5BLU	H5RED	UNUSED
62	O2	P2	H6	D7RED	D4RED	D6RED	D3RED	C6GRN	F6BLU	H6RED	UNUSED
63	O3	P3	H7	(NOTE 4)	UNUSED	D7RED	D4RED	C7GRN	F7BLU	H7RED	UNUSED

Note 1: In 4 BPP mode the 4 most significant bits of each pixel come from the partition bits of the palette control register.  
 Note 2: For 15/16 BPP Direct Color the low order bits for each color component are determined by the ZIB/LIN Bit of the 16 BPP Control register. For 15/16 BPP sparse format (indirect color), the ZIB/LIN bit must be set to ZIB, and the low order bits for each color component will be zeroes.  
 Note 3: In CONTIGUOUS format for 15/16 BPP the most significant bits of each pixel come from the partition bits of the palette control register.  
 Note 4: These bits are used for DYNAMIC BYPASS when that mode is enabled, otherwise they are unused.

## 4.0 Controls

### 4.1 Blank and Border Control

The  $\overline{\text{BLANK}}$  and  $\overline{\text{BORDER}}$  signals control the way in which data is presented to the DACs. These control signals are used to determine when pixel data is valid, when the border color is to be displayed, where the cursor should be located on the screen, and how the MISR will accumulate its signature.

### 4.2 Blanking Control

$\overline{\text{BLANK}}$  is latched by the rising edge of LCLK. When  $\overline{\text{BLANK}}$  is active (low), the data presented to the DACs is forced to zeroes. When  $\overline{\text{BLANK}}$  is inactive (high), the pixel data or VGA data is considered valid (unless  $\overline{\text{BORDER}}$  is active), and the data is presented to the DACs as determined by the current mode of operation. Cursor data will override pixel data when the cursor is to be displayed.

### 4.3 Vertical Blanking

When  $\overline{\text{BLANK}}$  is active (low) an internal counter is used to determine whether or not the current blanking interval is vertical blanking. If the counter reaches its maximum count of 2048 pixels, an internal signal will become active to indicate that the end of the current frame has been reached. This internal signal will remain active until  $\overline{\text{BLANK}}$  becomes inactive (high). This vertical blanking detection is used by the cursor logic to position the cursor (if enabled) in the following frame. It is also used by the MISR (if enabled) to control the accumulation of a signature for one complete frame of pixel data.

### 4.4 Border Control

$\overline{\text{BORDER}}$  is latched by the rising edge of LCLK. When  $\overline{\text{BLANK}}$  is active (low),  $\overline{\text{BORDER}}$  must also be active (low). When  $\overline{\text{BLANK}}$  is inactive (high), the state of  $\overline{\text{BORDER}}$  will determine whether or not the color in the Border Color registers is displayed. If  $\overline{\text{BORDER}}$  is active (low), the border color is displayed, and if  $\overline{\text{BORDER}}$  is inactive (high), the pixel data or cursor data is displayed. For cursor positioning, the active display area is considered valid when  $\overline{\text{BORDER}}$  and  $\overline{\text{BLANK}}$  are both inactive (high). The MISR signature is accumulated when  $\overline{\text{BLANK}}$  alone is inactive (high), thus the border area is included in the MISR accumulation. If no border is required, the  $\overline{\text{BORDER}}$  input should be tied to  $\overline{\text{BLANK}}$ .

The intent of the  $\overline{\text{BORDER}}$  signal is to create a "picture frame" around the active display area.  $\overline{\text{BORDER}}$  can remain active (low) for entire scan lines at the top and bottom of the active display area, or it can be active at the beginning and end of each scan line to create this effect. Other changes in the  $\overline{\text{BORDER}}$  signal within the active display area are not allowed.

### 4.5 Sync Control

Three sync signals,  $\overline{\text{HSYNCIN}}$ ,  $\overline{\text{VSYNCIN}}$ , and  $\overline{\text{CSYNCIN}}$  are brought into the device.

Four registers control what is done with these signals:

- Sync Control (index 0x0003)
- Horizontal Sync Position (index 0x0004)
- DAC Operation (index 0x0006)
- Power Management (index 0x0005)

Horizontal sync on  $\overline{\text{HSYNCIN}}$  is processed and sent out on  $\overline{\text{HSYNCOUT}}$ . Vertical sync on  $\overline{\text{VSYNCIN}}$  is processed and sent out on  $\overline{\text{VSYNCOUT}}$ .

The intent of processing horizontal sync is to delay it to match the delay seen by the pixel data from the inputs (VGA[7:0] or PIX[63:0]) to the DAC outputs. In addition, the signal may be inverted, forced low or high, or 3-stated.

A mismatch between pixel delay and horizontal sync delay can cause a visible effect, that is, the display may not be centered horizontally on the screen. The vertical display timings are generally such that mismatches are not visible. Vertical sync is brought in on  $\overline{\text{VSYNCIN}}$  and sent out on  $\overline{\text{VSYNCOUT}}$  to provide the same invert, force low or high, and 3-state controls as provided for horizontal sync.

Composite sync on  $\overline{\text{CSYNCIN}}$  may be injected onto the Green DAC output for composite-sync-on-green. This function is enabled by setting the SOG bit of the DAC Operation register. If this bit is off  $\overline{\text{CSYNCIN}}$  is not used.

The composite sync is delayed internally to match the pixel pipeline delay.

## 4.6 Clocking and Pipeline Delay

### 4.6.1 Horizontal Sync

The clocking and delay of  $\overline{\text{HSYNCIN}}$  to  $\overline{\text{HSYNCOUT}}$  depends on the DLY CNTL bit of the Sync Control register. If this bit is set to 1,  $\overline{\text{HSYNCIN}}$  is passed directly to  $\overline{\text{HSYNCOUT}}$  without latching and without pipeline delay matching.

If DLY CNTL is set to 0 and SOG is off (no composite sync), then  $\overline{\text{HSYNCIN}}$  is latched on the rising edge of LCLK and delayed internally to match the pixel pipeline delay before being sent out on  $\overline{\text{HSYNCOUT}}$ . Also, additional delay may be added with the Horizontal Position register (see section below).

If SOG is on (composite sync) then DLY CNTL has no effect and  $\overline{\text{HSYNCIN}}$  is passed directly to  $\overline{\text{HSYNCOUT}}$  without latching and without pipeline delay matching.

### 4.6.2 Vertical Sync

$\overline{\text{VSYNCIN}}$  is passed directly to  $\overline{\text{VSYNCOUT}}$  without latching and without pipeline delay matching.

### 4.6.3 Composite Sync

The  $\overline{\text{CSYNCIN}}$  input is always latched on the rising edge of LCLK. When enabled with the SOG bit, it is delayed internally to match the pipeline delay of the pixel data, and then is injected onto the Green DAC output. As with horizontal sync, additional delay can be added with the Horizontal Sync Position register.

### 4.6.4 Horizontal Position Control

Additional delay of 0 to 15 pixel clock periods may be added to the horizontal sync and composite sync signals with the Horizontal Sync Position register.

The intent of this additional delay is to provide a "fine tune" control of the horizontal screen position. Typically the incoming sync signals can only be adjusted in multiples of the pixel clock. The additional delay added with the Horizontal Position Control register adjusts the screen position with pixel increments.

The Horizontal Position register can be used on horizontal sync when DLY CNTL is set to 0 and SOG is off. The register can be used with composite sync when SOG is on.

## 4.7 Additional Sync Control

The polarity of the received  $\overline{\text{CSYNCIN}}$  input may be inverted before it is applied to the green DAC using the CSYN INVT bit of the Sync Control register.

The polarity may be inverted between  $\overline{\text{HSYNCIN}}$  and  $\overline{\text{HSYNCOUT}}$  using the HSYN INVT bit, and the polarity may be inverted between  $\overline{\text{VSYNCIN}}$  and  $\overline{\text{VSYNCOUT}}$  using the VSYN INVT bit.

The  $\overline{\text{HSYNCOUT}}$  and  $\overline{\text{VSYNCOUT}}$  signals may be individually forced low, forced high, or forced to high impedance using the HSYN CNTL and VSYN CNTL bits of the Sync Control register.

As discussed in 7.3, "Clocking Power," on page 21, the clocks to the sync delay circuits can be shut off with the SYNC PWR bit of the Power Management register.

## 4.8 24 Bit Packed Pixel Control

The 24 bit packed pixel format requires special consideration. In this mode the pixel data at the beginning of a line must be aligned on an 8-pixel boundary as shown in Figure 2 on page 12. These eight pixels correspond to three 64-bit pixel port loads or three SCLK cycles. In order to keep pixel data and control signals properly aligned, all control signals ( $\overline{\text{BLANK}}$ ,  $\overline{\text{BORDER}}$ ,  $\overline{\text{HSYNCIN}}$ ,  $\overline{\text{VSYNCIN}}$ , and  $\overline{\text{CSYNCIN}}$ ) are required to change in increments of 8 pixels (3 SCLKS). When either  $\overline{\text{BLANK}}$  or  $\overline{\text{BORDER}}$  changes to indicate the beginning of an active display line, it is assumed that the pixel data which begins that line is aligned on the proper 8-pixel boundary.

## 5.0 Cursor Operation

The cursor is a 32x32 or 64x64 pixel pattern that is overlaid on the display pixels just before presentation to the DACs. The cursor size, 32x32 or 64x64 is set with the CURS SIZE bit of the Cursor Control register.

Pixel columns are numbered left to right starting with 0. Pixel rows are numbered top to bottom starting with 0.

### 5.1 Cursor Enable

The cursor is enabled when the CURSOR MODE bits of the Cursor Control register are not 00. When enabled, the cursor will display if it has not been moved off-screen. If disabled (CURSOR MODE = 00), the cursor will not be displayed.

The cursor may be used with either pixel port (VGA or PIX), with any of the pixel formats (VGA, 4, 8, 15/16, 24, 32 BPP), and with indirect or direct color.

### 5.2 Cursor Array

The cursor image is stored in the Cursor Array. The array is organized 1024x8 (1024 bytes). It is accessed as Indexed Data using index addresses 0x0100 through 0x04ff.

Each pixel of the cursor uses 2 bits, thus 4 cursor pixels are stored in each byte of the array. The entire array is used to contain the 64x64 cursor image (4 pixels/byte × 1024 bytes = 4096 pixels = 64x64).

For the 32x32 cursor only 256 bytes are required (4 pixels/byte × 256 bytes = 1024 pixels = 32x32). The cursor array is divided into four contiguous slots to allow the storage of four cursor images. The SMLC SLOT bits of the Cursor Control register are used to select one of the four slots for display. The SMLC SLOT bits have no effect when the cursor size is 64x64.

Storage of the cursor within the array starts with the top row. For the 64x64 cursor the first 16 bytes hold row 0, the next 16 bytes hold row 1, and so on, starting with the first byte in the array at index address 0x0100.

For the 32x32 cursor the first 8 bytes hold row 0, the next 8 bytes hold row 1, and so on, starting with the first byte in a slot (index addresses 0x0100, 0x0200, 0x0300 or 0x0400).

Within a row the pixels are stored left to right in groups of four. The first byte holds pixels 0, 1, 2, 3, the next byte holds pixels 4, 5, 6, 7, and so on.

Within a byte the four pixels may be stored right to left or left to right, depending on the PIX ORDR bit of the Cursor Control register. If PIX ORDR = 0 the pixels are stored right to left (3, 2, 1, 0); if PIX ORDR = 1 the pixels are stored left to right (0, 1, 2, 3).

#### 5.2.1 Cursor Array Access

Cursor Array writes and reads are synchronized with the internal pixel clock, so the pixel clock must be running for microprocessor accesses to be valid. If this condition is met, the cursor array may be written or read at any time.

Microprocessor read accesses of the cursor array may disturb the cursor image if it is being displayed at that time. However, no more than one cursor pixel will be disturbed per cursor read access. Microprocessor write accesses of the cursor array will not disturb the cursor.

#### 5.2.2 Cursor Array Writes

A write to the cursor array is accomplished by writing the Index High and Index Low registers with an index address for the array (0x0100 – 0x04ff), followed by a write of the desired data to Index Data. If auto-increment is turned on, the entire array may be written sequentially by repeated writes to Index Data.

#### 5.2.3 Cursor Array Reads

To meet the bus timings for reads, the cursor array read data is pre-fetched. A pre-fetch is triggered by writing the Index High or Index Low register such that the resulting index address is for an entry in the array (0x0100 .. 0x04ff). At the end of the write cycle the cursor array will be read at the address held in the index address registers, and the read data will be held in an internal register. A subsequent read of Index Data will read this pre-fetched data. At the end of the read another pre-fetch will be triggered. If auto-increment is turned on, this pre-fetch will be for the next address in the array. Thus, the entire array can be read by repeated reads from Index Data.

The pre-fetching of cursor array data will stop if

1. The index register auto-increments beyond 0x04ff
- OR
2. A write is done to Index Data.



### 5.3 Cursor Modes

Each pixel of the cursor is specified with 2 bits. There are three ways that these 2 bits can be used, as specified by the CURSOR MODE bits of the Cursor Control register. These are shown in Table 8, "Cursor Modes," on page 18.

There are three cursor colors that may be displayed. The colors are stored in the Cursor Color 1 Red, Green, Blue, Cursor Color 2 Red, Green, Blue, and Cursor Color 3 Red, Green, Blue registers. Each red, green, and blue register is 8 bits, yielding a full 24-bit color for each of the three cursor colors. The cursor color is always 24 bits, and is not affected by the COL RES or 6BIT LIN control bits, or any of the pixel formats (VGA, 4, 8, 15/16, 24, 32 BPP).

Cursor Mode 0 allows selection of any of the three colors while Modes 1 and 2 allow selection between colors 1 and 2.

All modes can specify that the cursor pixel be transparent, to allow the underlying display pixel to be displayed. This pixel will either be a palette output or a formatted VRAM pixel, depending on whether the pixel format is VGA or indirect color, or direct color.

Mode 1 can also specify that the complement of the underlying display pixel be displayed. The intent is to highlight the cursor by "reversing" the color of the background pixels.

### 5.4 Cursor Hot Spot

The hot spot is the point within the cursor that is used to locate the cursor's position on the screen. Any pixel within the cursor may be identified as the hot spot.

The Cursor Hot Spot X and Cursor Hot Spot Y registers hold the unsigned cursor pixel X (column) and Y (row) coordinates for the hot spot. The range for the X and Y values is 0 to 31 for the 32x32 cursor and 0 to 63 for the 64x64 cursor.

### 5.5 Cursor Position

The Cursor X Low, Cursor X High, Cursor Y Low, and Cursor Y High registers specify the position of the cursor (the cursor hot spot) on the screen.

The X and Y positions are specified as *signed* numbers in two's complement format. The High and Low pairs yield 16-bit position registers, of which 12 bits plus a sign bit are used.

The hardware automatically extends the sign bit into the unused bit positions of the position registers. The valid X and Y ranges are -4096 to +4095.

The X and Y screen coordinates are for non-border display pixels. (0,0) is the upper left corner pixel of the screen that is not in the border area. The X value increases positively left-to-right, and the Y value increases positively top-to-bottom. Negative X values are to the left of the non-border display area and negative Y values are above the top of the non-border display area.

The cursor is clipped by the edges of the screen if there is no border, or by the border if a border is used. For example, if the hot spot is (0,0) the full cursor will be displayed in the upper left corner if the X position is +0 and the Y position is +0. If the X value is changed to -1 (0xffff) only columns 1 through 31 of the cursor will be displayed. If the X value is -31 (0xffe1) only column 31 of the cursor will be displayed. If the X value is more negative than -31 the cursor will not be displayed.

### 5.6 Interlace

The selection of cursor rows for display is changed if interlace mode is specified. This is controlled with the INTL MODE bit of the Miscellaneous Control 2 register.

In non-interlaced mode, the cursor rows are displayed sequentially, starting with the first non-clipped row to be displayed based on the Y position and Y Hot Spot register contents.

When interlaced mode is specified, the ODD/ $\overline{\text{EVEN}}$  signal is used to determine if odd or even scan lines are being displayed. If ODD/ $\overline{\text{EVEN}}$  is low (even field), the first non-clipped cursor row that falls on an even scan line is displayed. Similarly, if ODD/ $\overline{\text{EVEN}}$  is high (odd field), the first non-clipped cursor row that falls on an odd scan line is displayed. In either case, if the first cursor line displayed is an even-numbered cursor row (as determined by Y Position and Y Hot Spot) then successive even-numbered cursor rows will be displayed during that field. If the first cursor line displayed is an odd-numbered cursor row then successive odd-numbered cursor rows will be displayed during that field.

ODD/ $\overline{\text{EVEN}}$  should only change during vertical blanking time for proper cursor display.

## 5.7 Cursor Update and Display

### 5.7.1 Position

Writing any of the Cursor X Low, Cursor X High, or Cursor Y Low registers will not affect the position of the cursor on the screen. When the Cursor Y High register is written, the X and Y positions are captured in a second set of registers.

When vertical blanking is detected (see 4.3, "Vertical Blanking," on page 15), the "captured" X and Y positions are sampled. The sampled position is saved until it is re-sampled on the next vertical blanking time. Between vertical blanking times the sampled position is used, along with the Cursor Hot Spot, to calculate which pixels of the cursor are used and where they are displayed on the screen.

When INTL MODE is set the ODD/EVEN signal is examined at the end of vertical blanking to determine if only even or only odd rows will be displayed.

### 5.7.2 Controls

When vertical blanking is detected the Cursor Control register is sampled along with the X and Y position registers. This allows the cursor to be toggled on and off on a frame-by-frame basis with the CURSOR MODE bits, and if the cursor is 32x32, it allows toggling among the four slots on a frame-by-frame basis using the SMLC SLOT bits.

Note that in interlace mode the sampling is on a field-by-field basis. Also, since the PIX ORDER and CURS SIZE bits are also sampled these functions will only change when vertical blanking is detected.

### 5.7.3 Other

Changes to the Cursor Color registers and the Cursor X and Y Hot Spot registers are propagated to the cursor logic as soon as they are made, so if they are updated while the cursor is being displayed the cursor image will be disturbed.

Changes to the cursor array are also propagated to the cursor logic as soon as they are made. Also, as noted above, microprocessor read accesses of the cursor array may interfere with the cursor display logic. For example, with a 32x32 cursor being displayed from slot 0, microprocessor read accesses to slot 1 may cause the display of the slot 0 cursor to be disturbed.

It is recommended that Cursor Array Reads and changes to the Cursor Color registers and the Cursor X and Y Hot Spot registers be made only when the cursor is disabled, off screen, or during vertical blanking time.

Table 8. Cursor Modes

CURSOR PIXELS	CURSOR MODE		
	Mode 0 CURSOR MODE = 01	Mode 1 CURSOR MODE = 10	Mode 2 CURSOR MODE = 11
00	Transparent	Cursor Color 1	Transparent
01	Cursor Color 1	Cursor Color 2	Transparent
10	Cursor Color 2	Transparent	Cursor Color 1
11	Cursor Color 3	Complement	Cursor Color 2

---

## 8.0 Diagnostic Support

### 8.1 Data Masks

The Pixel data inputs may be masked by the VRAM Mask registers to diagnose frame buffer problems. Each active bit in the VRAM Mask register controls four bits of the pixel port. Masked bytes introduce zeroes into the data path.

### 8.2 MISR

The MISR employs a 24-bit shift register with feedback to accumulate a signature of the data presented to the DACs during one screen frame. Signature accumulation is controlled by vertical blanking detection and Miscellaneous Control 1 register bit 7. After MC1(7) changes from '0'b to '1'b, vertical blanking resets the signature to zero at the start of a frame. Signature accumulation ends when vertical blanking goes "on" to end a frame, regardless of the state of MC1(7). The MISR signature can now be read with three cycles from the microprocessor interface. MC1(7) must be written to a '0'b and then a '1'b before a new signature can be generated. In interlace mode, the MISR accumulates one complete frame starting with the ODD field.

### 8.3 DAC Comparators

Each DAC output is connected to a comparator. Both latched and unlatched copies of the comparator outputs can be read from the DAC Sense register. The logical AND of either the latched or unlatched comparator bits is presented on the  $\overline{\text{SENSE}}$  output. The reference inputs of the comparators are connected to the chip CVREF pin. With the internally applied reference voltage of 0.35 V, the corresponding Sense bit will be '1'b when the DAC output is 0 to 0.28 V or '0'b when it is 0.42 V to 0.70 V. These values apply when the DAC is doubly terminated in 75  $\Omega$ , RREF=698  $\Omega$ , and no sync or blank is present.

## 9.0 Internal Register - Summary

Table 8 is a summary of the internal registers, with more detailed descriptions for the Direct Access Registers, Indexed Registers, Pixel Representation, Frequency Selection, Cursor, Border Color and Diagnostic Support.

**Table 9. Internal Register Summary**

RS[2:0]	Index	R/W	Reset Value	Register Name
000	-	✓	U	Palette Address (Write Mode)
001	-	✓	U	Palette Data
010	-	✓	U	Pixel Mask
011	-	✓	U	Palette Address (Read Mode)
100	-	✓	U	Index Low
101	-	✓	U	Index High
110	-	✓	U	Index Data (Indexed Registers)
111	-	✓	U	Index Control
110	0x0000	RO	Rev	Revision Level
110	0x0001	RO	0x01	ID
110	0x0002	✓	0x00	Miscellaneous Clock Control
110	0x0003	✓	0x00	Sync Control
110	0x0004	✓	0x00	Horizontal Sync Position
110	0x0005	✓	0x00	Power Management
110	0x0006	✓	0x00	DAC Operation
110	0x0007	✓	0x00	Palette Control
110	0x0008 - 0x0009	-	-	(Reserved)
110	0x000a	✓	U	Pixel Format
110	0x000b	✓	U	8 BPP Control
110	0x000c	✓	U	16 BPP Control
110	0x000d	✓	U	24 BPP Packed Control
110	0x000e	✓	U	32 BPP Control
110	0x000f	-	-	(Reserved)
110	0x0010	✓	0x00	PLL Control 1
110	0x0011	✓	0x00	PLL Control 2
110	0x0012 - 0x0013	-	-	(Reserved)

**Table 9. Internal Register Summary (Continued)**

RS[2:0]	Index	R/W	Reset Value	Register Name
110	0x0014	✓	U	Fixed PLL Reference Divider
110	0x0015 - 0x001f	-	-	(Reserved)
110	0x0020	✓	0x00	F0 (M0)
110	0x0021	✓	0x00	F1 (N0)
110	0x0022	✓	0x00	F2 (M1)
110	0x0023	✓	0x00	F3 (N1)
110	0x0024	✓	0x00	F4 (M2)
110	0x0025	✓	0x00	F5 (N2)
110	0x0026	✓	0x00	F6 (M3)
110	0x0027	✓	0x00	F7 (N3)
110	0x0028	✓	0x00	F8 (M4)
110	0x0029	✓	0x00	F9 (N4)
110	0x002a	✓	0x00	F10 (M5)
110	0x002b	✓	0x00	F11 (N5)
110	0x002c	✓	0x00	F12 (M6)
110	0x002d	✓	0x00	F13 (N6)
110	0x002e	✓	0x00	F14 (M7)
110	0x002f	✓	0x00	F15 (N7)
110	0x0030	✓	0x00	Cursor Control
110	0x0031	✓	U	Cursor X Low
110	0x0032	✓	U	Cursor X High
110	0x0033	✓	U	Cursor Y Low
110	0x0034	✓	U	Cursor Y High
110	0x0035	✓	U	Cursor Hot Spot X
110	0x0036	✓	U	Cursor Hot Spot Y
110	0x0037 - 0x003f	-	-	(Reserved)
110	0x0040	✓	U	Cursor Color 1 Red
110	0x0041	✓	U	Cursor Color 1 Green
110	0x0042	✓	U	Cursor Color 1 Blue
110	0x0043	✓	U	Cursor Color 2 Red
110	0x0044	✓	U	Cursor Color 2 Green
110	0x0045	✓	U	Cursor Color 2 Blue
110	0x0046	✓	U	Cursor Color 3 Red
110	0x0047	✓	U	Cursor Color 3 Green
110	0x0048	✓	U	Cursor Color 3 Blue

**Table 9. Internal Register Summary (Continued)**

RS[2:0]	Index	R/W	Reset Value	Register Name
110	0x0049 - 0x005f	-	-	(Reserved)
110	0x0060	✓	U	Border Color Red
110	0x0061	✓	U	Border Color Green
110	0x0062	✓	U	Border Color Blue
110	0x0063 - 0x006f	-	-	(Reserved)
110	0x0070	✓	0x00	Miscellaneous Control 1
110	0x0071	✓	0x00	Miscellaneous Control 2
110	0x0072	✓	0x00	Miscellaneous Control 3
110	0x0073 - 0x0081	-	-	(Reserved)
110	0x0082	RO	U	DAC Sense
110	0x0083	-	-	(Reserved)
110	0x0084	RO	U	MISR Red
110	0x0085	-	-	(Reserved)
110	0x0086	RO	U	MISR Green
110	0x0087	-	-	(Reserved)
110	0x0088	RO	U	MISR Blue
110	0x0089 - 0x008d	-	-	(Reserved)
110	0x008e	RO	0x00	PLL VCO Divider Input
110	0x008f	RO	U	PLL Reference Divider Input
110	0x0090	✓	U	VRAM Mask Low
110	0x0091	✓	U	VRAM Mask High
110	0x0092 - 0x00ff	-	-	(Reserved)
110	0x0100 - 0x04ff	✓	U	Cursor Array
110	0x0500 - 0x07ff	-	-	(Reserved)

RO=Read Only, U=Undefined, Rev=Revision Level

## 10.0 Register Descriptions

### 10.1 Direct Access Registers

The direct access registers are addressed using RS[2:0] inputs.

#### Palette Address (Write Mode)

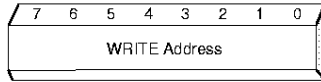

**RS[2:0]:** 000  
**Access:** Read/Write  
**Power on Value:** Undefined  
**Bits 7 - 0** WRITE Address - Palette address in write mode.

Operation of this register is discussed in 1.9, "Microprocessor Access," on page 2.

#### Palette Data

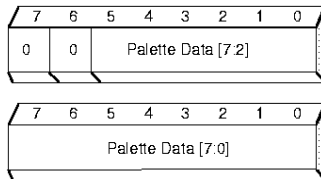

**RS[2:0]:** 001  
**Access:** Read/Write  
**Power on Value:** Undefined

The format of the palette data depends on the color resolution, 6 or 8 bit.

#### 6 bit color resolution

##### Miscellaneous Control 2 COL RES = 0

**Bits 7 - 6** 00  
**Bits 5 - 0** 6 bit palette data

On WRITES bits 7:6 from the microprocessor are discarded, bits 5:0 are written to bits 7:2 internally, and internal bits 1:0 are set to '00'. On reads internal bits 7:2 are read as bits 5:0, and bits 7:6 are returned as '00'.

#### 8 bit color resolution

##### Miscellaneous Control 2 COL RES = 1

**Bits 7-0** 8 bit palette data. Bits 7:0 are written/read internally as bits 7:0

Operation of this register is discussed in 1.9, "Microprocessor Access," on page 2.

#### Pixel Mask

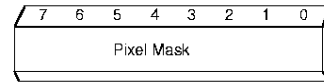

**RS[2:0]:** 010  
**Access:** Read/Write  
**Power on Value:** Undefined  
**Bits 7 - 0** Pixel Mask

In indirect color modes this register masks the pixel values used to index into the palettes. Each bit is ANDed with its corresponding pixel bit. A value of 0xff is required to pass the pixel values to the palettes unchanged.

The same mask is applied to each of the red, green, and blue pixel addresses into the palettes.

**Palette Address (Read Mode) / Palette Access State**

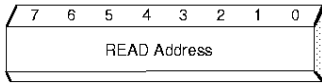

**RS[2:0]:** 011  
**Access:** Write  
**Power on Value:** -  
**Bits 7 - 0** READ Address - Palette address in read mode.

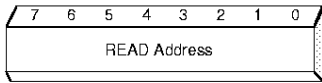

**RS[2:0]:** 011  
**Access:** Read  
**Power on Value:** Undefined  
**PADR RFMT:** 0  
**Bits 7 - 0** READ Address - Palette address in read mode.

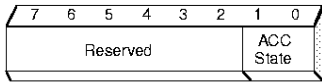

**RS[2:0]:** 011  
**Access:** Read  
**Power on Value:** Undefined  
**PADR RFMT:** 1  
**Bits 7 - 2** Reserved  
**Bits 1 - 0** ACC STATE - Palette Access State. Reports which mode was used on last write of Palette Address Register.  
 00 Write Mode  
 11 Read Mode

Note that the palette address to be read is written into this register, but the contents that are read depends on the PADR RFMT bit in the Miscellaneous Control 1 register. Operation of these registers is discussed in 1.6, "Microprocessor Access," on page 2.

**Index Low**

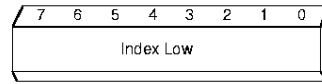

**RS[2:0]:** 100  
**Access:** Read/Write  
**Power on Value:** Undefined  
**Bits 7 - 0** Index Low

This register, together with Index High, forms the internal index register. It selects the register that will be accessed when the Indexed Data register is written or read.

**Index High**

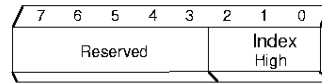

**RS[2:0]:** 101  
**Access:** Read/Write  
**Power on Value:** Undefined  
**Bits 7 - 3** Reserved  
**Bits 2 - 1** Index High

This register provides the high-order bits of the internal index register.

If auto-increment is turned on, the resulting index is not defined if an increment past the maximum index value occurs.

**Indexed Data**

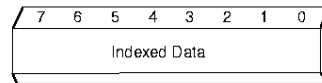

**RS[2:0]:** 110  
**Access:** Read/Write  
**Power on Value:** Undefined  
**Bits 7 - 0** Indexed Data

A write or read to this register will write or read the register addressed by the internal index register (Index High and Index Low).

Following a write or read to Indexed Data, the index register will be incremented if auto-increment is turned on (INDX CNTL bit of the Index Control register).

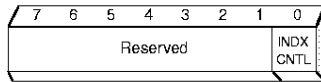
**Index Control**

**RS[2:0]:** 111

**Access:** Read/Write

**Power on Value:** Undefined

**Bits 7 - 1** Reserved

**Bit 0** INDX CNTL - Index Control. Controls auto-increment of the index register.

0 Off - no auto-increment.

1 On - the index register (Index High and Index Low) will increment by one following a write or read to Indexed Data.

**10.2 Indexed Registers**

The indexed registers are accessed by setting the desired address into the internal index register (Index High and Index Low) and writing or reading the Indexed Data register.

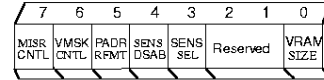
**10.2.1 Miscellaneous Control**
**Miscellaneous Control 1**

**Index:** 0x0070

**Access:** Read/Write

**Power on Value:** 0x00

**Bit 7** MISR CNTL

0 Off. If the MISR is running, it will stop at the beginning of the next frame.

1 On. The MISR will start accumulating a signature at the start of the next frame (end of vertical blanking).

**Bit 6** VMSK CNTL - VRAM Mask Control

0 No VRAM masking.

1 The VRAM inputs on the PIX[63:00] inputs will be masked under control of the VRAM Mask High and VRAM Mask Low registers.

This bit has no effect when the VGA port is selected.

**Bit 5** PADR RFMT - Palette Address Register (Read Mode) Format. Specifies the contents returned from the Palette Address register, read mode (RS[2:0] = 011)

0 Return the eight bits of the read address

1 Return the palette access state in the two low order bits

**Bit 4** SENS DSAB - SENSE Driver Disable

0 SENSE driver enabled

1 SENSE driver disabled (3-stated)

**Bit 3** SENS SEL - Sense Select. Selects which bit of the DAC Sense register is presented on the SENSE driver.

0 Bit 3 - Unlatched Sense

1 Bit 7 - Latched Sense

**Bits 2 - 1** Reserved

**Bit 0** VRAM SIZE - VRAM interface width

0 32 bits. PIX[31:0] used, PIX[63:32] ignored.

1 64 bits. PIX[63:00] used.

This bit has no effect when the VGA port is selected.



## Miscellaneous Control 2



**Index:** 0x0071

**Access:** Read/Write

**Power on Value:** 0x00

**Bits 7 - 6** PCLK SEL - Pixel Clock Select. Specifies the source of the internal pixel clock.

- 00 LCLK input
- 01 Internal PLL output
- 10 EXT OSC input
- 11 Reserved

**Note:** A selection of 00 (LCLK input) for the pixel clock is required and only valid when PORT SEL = 0 (VGA data inputs), or 32 BPP is selected with a VRAM width of 32.

**Bit 5** INTL MODE - Interlace Mode

- 0 Non-interlaced. The ODD/EVEN input is ignored.
- 1 Interlaced. If the cursor is turned on, the ODD/EVEN input will be used to select display of the odd or even cursor rows.

**Bit 4** BLANK CNTL - Blanking Control

- 0 Normal operation.
- 1 DACs are blanked. No pixel data is presented on the DACs, but all other operations remain normal, including the collection of a signature if the MISR is turned on.

**Bit 3** RSVD - Reserved

**Bit 2**

COL RES - Color Resolution

- 0 6-bit
- 1 8-bit

With 6-bit color resolution only 6 bits of microprocessor data are loaded into the palettes. Microprocessor data bits D[5:0] are written to/read from palette bits [7:2]. Internally 00 is written to palette bits [1:0], and on reads D[7:6] are forced to 00.

Also with 6-bit color resolution the two low order bits presented from the palettes to the DACs are controlled by Palette Control bit 6BIT LIN.

With 8-bit color resolution all 8 bits from/to the microprocessor are written/read to the palette, and the 8 bits presented to the DACs are unmodified. The 6BIT LIN bit has no effect.

**Bit 1**

RSVD - Reserved

**Bit 0**

PORT SEL - Port Select

- 0 VGA Data inputs.
- 1 VRAM pixel port inputs.

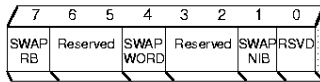
**Miscellaneous Control 3**

- Index:** 0x0072  
**Access:** Read/Write  
**Power on Value:** 0x00
- Bit 7** SWAP RB - Swap Red and Blue pixel components. In 16, 24, and 32 BPP, this bit causes the red and blue components of the pixels to be swapped. In indirect mode, the swapping takes place before the Palette.
- 0 Normal operation.
  - 1 Swap Red and Blue components of the pixel. This bit only has an effect in 16, 24, and 32 BPP.
- Bits 6 - 5** Reserved
- Bit 4** SWAP WORD - Swap incoming words. With a VRAM width of 64 this bit causes the order of the two incoming words (4 bytes each) to be swapped.
- 0 Use PIX[31:00] for first pixel(s), use PIX[63:32] for next pixel(s).
  - 1 Use PIX[63:32] for first pixel(s), use PIX[31:00] for next pixel(s).
- Bits 3 - 2** Reserved
- Bit 1** SWAP NIB - Swap nibbles within bytes. Used with 4 BPP.
- 0 Use high nibble (e.g., PIX[07:04]) for first pixel, use low nibble (e.g., PIX[03:00]) for next pixel.
  - 1 Use low nibble (e.g., PIX[03:00]) for first pixel, use high nibble (e.g., PIX[07:04]) for next pixel.
- The same nibble order is applied to each of the incoming bytes. This bit has no effect if the pixel format is not 4 BPP.
- Bit 0** Reserved

This register has no effect when the VGA port is selected.

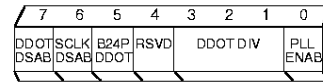
**Miscellaneous Clock Control**

- Index:** 0x0002  
**Access:** Read/Write  
**Power on Value:** 0x00
- Bit 7** DDOT DSAB - DDOTCLK driver disable
- 0 DDOTCLK driver enabled
  - 1 DDOTCLK driver disabled (3-stated)
- Bit 6** SCLK DSAB - SCLK driver disable
- 0 SCLK driver enabled
  - 1 SCLK driver disabled (3-stated)
- Bit 5** B24P DDOT - Selects which clock is driven on DDOTCLK when 24 Bit Packed Pixel format is selected.
- 0 Use divided PLL output under control of DDOT DIV bits.
  - 1 Output the same signal as SCLK.
- When a format other than 24 BPP Packed is selected, the B24P DDOT bit has no effect and the divided PLL output is used.
- Bit 4** RSVD - Reserved
- Bits 3 - 1** DDOT DIV - DDOTCLK divide factor. Specifies the divide factor applied to the internal PLL output to produce the DDOTCLK output signal.
- 000 PLL out/1
  - 001 PLL out/2
  - 010 PLL out/4
  - 011 PLL out/8
  - 100 PLL out/16
  - 101 Reserved
  - 110 Reserved
  - 111 Reserved
- Bit 0** PLL ENAB - PLL Enable
- 0 PLL programming disabled.
  - 1 PLL programming enabled.

**Sync Control**

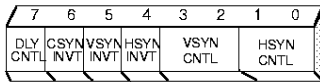

**Index:** 0x0003  
**Access:** Read/Write  
**Power on Value:** 0x00

**Bit 7** DLY CNTL - Sync Delay Control. Specifies whether delay matching the pixel pipeline delay should be added to the horizontal sync signal.  
 0 Add matching delay  
 1 Do not add delay  
 This bit only has effect when the SOG bit of the DAC Operation register is off. If SOG is on (composite sync enabled) then matching pipeline delay is not added to horizontal sync.

**Bit 6** CSYN INVT - Composite Sync Invert  
 0 Do not invert incoming CSYNCIN  
 1 Invert incoming  $\overline{\text{CSYNCIN}}$

**Bit 5** VSYN INVT - Vertical Sync Invert  
 0 Do not invert incoming  $\overline{\text{VSYNCIN}}$   
 1 Invert incoming  $\overline{\text{VSYNCIN}}$

**Bit 4** HSYN INVT - Horizontal Sync Invert  
 0 Do not invert incoming  $\overline{\text{HSYNCIN}}$   
 1 Invert incoming  $\overline{\text{HSYNCIN}}$

**Bits 3 - 2** VSYN CNTL - Vertical Sync Output Control  
 00 Normal output  
 01  $\overline{\text{VSYNCOUT}}$  forced high  
 10  $\overline{\text{VSYNCOUT}}$  forced low  
 11  $\overline{\text{VSYNCOUT}}$  disabled (3-stated)

**Bits 1 - 0** HSYN CNTL - Horizontal Sync Output Control  
 00 Normal output  
 01  $\overline{\text{HSYNCOUT}}$  forced high  
 10  $\overline{\text{HSYNCOUT}}$  forced low  
 11  $\overline{\text{HSYNCOUT}}$  disabled (3-stated)

**Horizontal Sync Control**

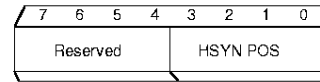

**Index:** 0x0004  
**Access:** Read/Write  
**Power on Value:** 0x00

**Bits 7 - 4** Reserved

**Bits 3 - 0** HSYN POS - Horizontal Sync Position. Specifies number of additional pixel delays to add to the horizontal sync signal and the composite sync signal.

0000	0 pixels
0001	1 pixel
0010	2 pixels
0011	3 pixels
0100	4 pixels
0101	5 pixels
0110	6 pixels
0111	7 pixels
1000	8 pixels
1001	9 pixels
1010	10 pixels
1011	11 pixels
1100	12 pixels
1101	13 pixels
1110	14 pixels
1111	15 pixels

If the SOG bit of the DAC Operation register is on, the additional pixel delays are added to composite sync. If SOG is off, then the delays are added to horizontal sync, under the control of the DLY CNTL bit of the Sync Control register. (The additional delay specified by the Horizontal Position register will only be added if DLY CNTL is set to 0.)

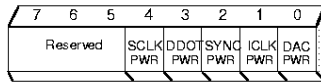
**Power Management**

- Index:** 0x0005  
**Access:** Read/Write  
**Power on Value:** 0x00  
**Bits 7 - 5:** Reserved  
**Bit 4:** SCLK PWR - SCLK Power Control  
 0 Normal Operation  
 1 Disable clocks to SCLK generator  
**Bit 3:** DDOT PWR - DDOTCLK Power Control  
 0 Normal Operation  
 1 Disable clocks to DDOTCLK generator  
**Bit 2:** SYNC PWR - Sync Power Control  
 0 Normal Operation  
 1 Disable clocks to horizontal and vertical sync circuits  
**Bit 1:** ICLK PWR - Internal Clock Power Control  
 0 Normal Operation  
 1 Disable all internal clocks except those for the SCLK generator, DDOTCLK generator, and horizontal and vertical sync circuits.  
 A clock is left running to allow microprocessor access of the palette and cursor array, but otherwise the palette and cursor RAMs will not be clocked. The two RAMs will retain their contents.  
**Bit 0:** DAC PWR - DAC Analog Power Control  
 0 Normal Operation  
 1 Disable analog power to the DACs

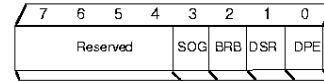
**DAC Operation**

- Index:** 0x0006  
**Access:** Read/Write  
**Power on Value:** 0x00  
**Bits 7 - 4:** Reserved  
**Bit 3:** SOG - Composite Sync-On-Green  
 0 Sync is disabled on Green DAC.  
 1 Sync is enabled on Green DAC.  
**Bit 2:** BRB - Blank Red and Blue DACs  
 0 Red and Blue DACs have normal function.  
 1 Red and Blue DACs are always blanked.  
**Bit 1:** DSR - DAC Slew Rate  
 0 Slow - typically 14 ns  
 1 Fast - typically 2 ns  
**Bit 0:** DPE - DAC blanking Pedestal Enable  
 0 Blanking pedestal disabled (0 IRE)  
 1 Blanking pedestal enabled (7.5 IRE)

**Palette Control**

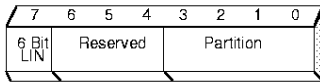

**Index:** 0x0007

**Access:** Read/Write

**Power on Value:** 0x00

**Bit 7** 6BIT LIN - 6 Bit Linear Color  
 0 Apply linear palette output  
 1 Do not apply linear palette output

This bit only has effect with indirect color modes, and when Color Resolution is set to 6 bits (Miscellaneous Control 2 COL RES bit = 0). For the 8 bits of palette output for each color, the high order two bits 7 and 6 will be substituted for the two low order bits 1 and 0.

**Bits 6 - 4** Reserved.

**Bits 3 - 0** PALETTE PARTITION - Selects which partition to use within the palettes when the pixel format is either 4 BPP, 15 BPP indirect color, or 16 BPP indirect color.

With 4 BPP the palettes are divided into 16 partitions. Each partition contains 16 entries. Bits 3 - 0 select 1 of the 16 partitions.

With 15 BPP (555) indirect color, the palettes are divided into 8 partitions. Each partition contains 32 entries. Bits 3 - 1 select 1 of the 8 partitions and bit 0 is not used.

With 16 BPP (565) indirect color, the palettes are divided into 4 partitions. Each partition contains 64 entries. All 64 entries of the Green palette are used in each partition. For the Red and Blue palettes only the first 32 entries of each partition are used. Bits 3 - 2 select 1 of the 4 partitions and bits 1 and 0 are not used.

The PARTITION bits have no effect when the pixel format is not 4 BPP, 15 BPP, or 16 BPP. Also, with 15 BPP and 16 BPP the PARTITION bits have no effect unless

1. Indirect color is chosen (16 BPP Control register bits B16 DCOL = 00), AND

2. Contiguous addressing is chosen (16 BPP Control register bit SPR/CNT = 1).

**10.2.2 Pixel Representation**

**Pixel Format**

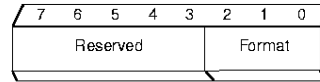

**Index:** 0x000a

**Access:** Read/Write

**Power on Value:** Undefined

**Bits 7 - 3** Reserved

**Bits 2 - 0** Pixel Format

000	Reserved
001	Reserved
010	4 BPP
011	8 BPP
100	15/16 BPP
101	24 BPP Packed
110	32 BPP
111	Reserved

This register has no effect when the VGA port is selected.

The 24 BPP Packed format requires the VRAM SIZE (Miscellaneous Control 1 register bit 0) to be set for 64 bits. If VRAM SIZE is set to 32 bits, the product operation will be undefined if the 24 BPP Packed format is selected.

**8 Bit Pixel Control**

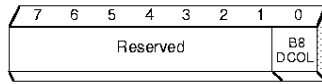

**Index:** 0x000b  
**Access:** Read/Write  
**Power on Value:** Undefined  
**Bits 7 - 1** Reserved  
**Bit 0** B8 DCOL - 8 BPP Direct Color Control

0 Indirect Color (through the palette).

1 Direct Color (palette bypass). Since the same 8-bit value will be applied to each of the Red, Green, and Blue DACs a monochrome image will be displayed.

This register only affects 8 BPP mode.

**16 Bit Pixel Control**

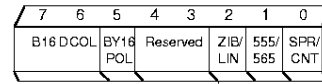

**Index:** 0x000c  
**Access:** Read/Write  
**Power on Value:** Undefined  
**Bits 7 - 6** B16 DCOL - 16 BPP Direct Color Control

00 Indirect Color (always goes through the palette). Either the 555 or 565 format can be selected. The SPR/CNT bit determines if the access of the palettes is sparse or contiguous. If CNT (contiguous), then the PARTITION bits of the Palette Control register determine which partition of the palettes is used. If SPR (Sparse) the ZIB/LIN bit must be set to 0 (ZIB).

01 Dynamic Bypass. The high order bit of each 16-bit pixel (PIX[15], PIX[31], PIX[47], PIX[63]) is used to select on a pixel-by-pixel basis to either go through the palette (indirect color) or bypass the palette (direct color). When this mode is selected the following conditions apply:

1. The 555/565 bit has no effect. Internally, the pixel format is forced to 5 bits per color (555).
2. The SPR/CNT bit has no effect. Internally, sparse addressing (SPR) is forced for palette access.
3. The ZIB/LIN bit has no effect. Internally, the low order bits for each color are forced to '0's (ZIB) for both access of the palette (indirect color) and palette bypass (direct color).
4. The Pixel Mask is applied to the pixel data regardless of whether or not the palette is bypassed.

10 Reserved

11 Direct Color (always bypasses the palette). Either the 555 or

565 format can be selected. The ZIB/LIN bit determines the expansion to 24 bits (low order bit fill). The SPR/CNT bit has no effect.

**Bit 5** BY16 POL - Bypass control bit polarity. Determines the meaning of the dynamic bypass control bit (PIX[15], PIX[31], PIX[47], PIX[63]).

0 Control Bit Forces Bypass

**Control Bit Pixel Path**

- 0 Through Palette (Indirect Color)
- 1 Bypass Palette (Direct Color)

1 Control Bit Forces Lookup

**Control Bit Pixel Path**

- 0 Bypass Palette (Direct Color)
- 1 Through Palette (Indirect Color)

The BY16 POL bit has no effect unless the B16 DCOL bits are set to 01.

**Bits 4 - 3** Reserved

**Bit 2** ZIB/LIN - Bit fill selection. For direct color this bit specifies how the low order bits of each color, R,G,B are filled when 555 or 565 formats are expanded to 24 bits.

- 0 ZIB - Zero Intensity Black. Low order bits are set to 0.
- 1 LIN - Linear. The low order bits are set to the values of the high order bits.

For indirect color if CNT (contiguous) addressing is selected, then ZIB/LIN has no effect. If SPR (sparse) addressing is selected then ZIB/LIN **must** be set to 0 (ZIB). The palette addressing is undefined if LIN bit fill is selected with sparse addressing.

**Bit 1** 555/565 - Selects 5 bits per color (555) or 5 red, 6 green, 5 blue (565).

- 0 555
- 1 565

**Bit 0** SPR/CNT - Sparse/Continuous. In indirect mode, selects whether index into palette is sparse or contiguous.

- 0 Sparse
- 1 Contiguous

This register only affects 15/16 BPP mode.

**24 Bit Packed Pixel Control**

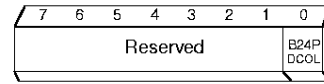

- Index:** 0x000d
- Access:** Read/Write
- Power on Value:** Undefined
- Bits 7 - 1** Reserved
- Bit 0** B24P DCOL - 24 BPP Packed Direct Color Control
  - 0 Indirect Color (through the palette).
  - 1 Direct Color (palette bypass).

This register only affects 24 BPP Packed mode.

**32 Bit Pixel Control**

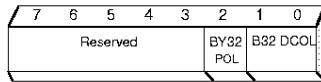

**Index:** 0x000e  
**Access:** Read/Write  
**Power on Value:** Undefined  
**Bit 7 - 3** Reserved  
**Bit 2** BY32 POL - Bypass control bit polarity. Determines the meaning of the dynamic bypass control bit (PIX[24], PIX[56]).

**0** Control Bit Forces Bypass  
*Control Bit Pixel Path*

0	Through Palette (Indirect Color)
1	Bypass Palette (Direct Color)

**1** Control Bit Forces Lookup  
*Control Bit Pixel Path*

0	Bypass Palette (Direct Color)
1	Through Palette (Indirect Color)

The BY32 POL bit has no effect unless the B32 DCOL bits are set to 01

**Bits 1 - 0**

**B32 DCOL - 32 BPP Direct Color Control**

- 00 Indirect Color (always goes through the palette). 24 bits (8 bits each for Red, Green, Blue) are used to index into the palettes. The 8 high order bits (PIX[31:24], PIX[63:56]) are not used.
- 01 Dynamic Bypass. A control bit in the high order byte (PIX[24], PIX[56]) is used to select on a pixel-by-pixel basis to either go through the palette (indirect color) or bypass the palette (direct color). The remaining bits in the high order byte (PIX[31:25], PIX[63:57]) are not used. In this mode, the Pixel Mask is applied to the pixel data regardless of whether or not the palette is bypassed.
- 10 Reserved
- 11 Direct Color (always bypasses the palette). 24 bits (8 bits each for Red, Green, Blue) are presented to the DACs. The 8 high order bits (PIX[31:24], PIX[63:56]) are not used.

This register only affects 32 BPP mode.



### 10.2.3 Frequency Selection

#### PLL Control 1

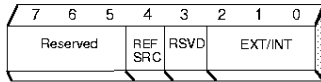

**Index:** 0x0010  
**Access:** Read/Write  
**Power on Value:** 0x00  
**Bits 7 - 5** Reserved  
**Bit 4** REF SRC - PLL Reference Source  
 Selects the reference clock input to the PLL.  
 0 REFCLK input  
 1 EXTCLK input  
**Bit 3** RSVD - Reserved  
**Bits 2 - 0** EXT/INT  
 Determines the source and selection for the PLL programming registers.  
 000 External FS[3:0] inputs  
 One of the F0 - F15 registers is selected with external signals FS[3:0]. The selected register provides the PLL VCO divider value. The Fixed PLL Reference Divider register is used to pre-scale the PLL reference clock.  
 001 External FS[2:0] inputs (8 value M/N programming)  
 Eight pairs of registers M0/N0, M1/N1, M2/N2, M3/N3, M4/N4, M5/N5, M6/N6, M7/N7 are selected with external signals FS[2:0] to provide the VCO divider/reference divider inputs to the PLL.  
 The Fixed PLL Reference Divider register is not used. FS[3] has no effect.

010 PLL Control 2 register bits [3:0] (16 value direct programming)  
 One of the F0 - F15 registers is selected with PLL Control 2 register bits [3:0]. The selected register provides the PLL VCO divider value. The Fixed PLL Reference Divider register is used to prescale the PLL reference clock.  
 011 PLL Control 2 register bits [2:0] (8 value M/N direct programming)  
 Eight pairs of registers M0/N0, M1/N1, M2/N2, M3/N3, M4/N4, M5/N5, M6/N6, M7/N7 are selected with PLL Control 2 register bits [2:0] to provide the VCO divider/reference divider inputs to the PLL.  
 The Fixed PLL Reference Divider register is not used. PLL Control 2 register bit 3 has no effect.  
 100 Reserved  
 101 Reserved  
 110 Reserved  
 111 Reserved

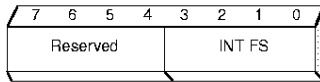
**PLL Control 2**

**Index:** 0x0011  
**Access:** Read/Write  
**Power on Value:** 0x00  
**Bits 7 - 3** Reserved  
**Bits 3 - 0** INT FS - Internal Frequency Selection. Identifies which PLL programming registers to use when PLL Control 1 register bits EXT/INT specify internal frequency selection (EXT/INT = 010 or 011).

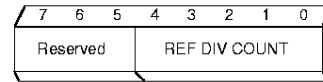
**Fixed PLL Reference Divider**

**Index:** 0x0014  
**Access:** Read/Write  
**Power on Value:** Undefined  
**Bits 7 - 5** Reserved  
**Bits 4 - 0** REF DIV COUNT - Reference Divide Count

EXT/INT = 000 or 010		EXT/INT = 001 or 011	
FS[3:0]	Selected Register	FS[2:0]	Selected Register
0000	F0	000	M0, N0
0001	F1	001	M1, N1
0010	F2	010	M2, N2
0011	F3	011	M3, N3
0100	F4	100	M4, N4
0101	F5	101	M5, N5
0110	F6	110	M6, N6
0111	F7	111	M7, N7
1000	F8	<b>Note:</b> FS[3:0] can come from the FS[3:0] chip inputs or the FS[3:0] register bits, depending on the EXT/INT bits of the PLL Control 1 register. For EXT/INT = 001 or 011, the FS[3] input is not used.	
1001	F9		
1010	F10		
1011	F11		
1100	F12		
1101	F13		
1110	F14		
1111	F15		

**F0-F15: Frequency 0 to Frequency 15**

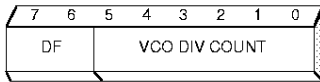

**Index:** 0x0020 - 0x002f  
**Access:** Read/Write  
**Power on Value:** 0x00  
**Bits 7 - 6** DF - Desired Frequency  
**Bits 5 - 0** VCO DIV COUNT - VCO Divide Count

The above register diagram shows the format for the 16 frequency registers F0 - F15. This format is selected when the EXT/INT bits (PLL Control 1 register, bits 2:0) = 000 or 010. The selected F0-F15 register provides the PLL with the DF value and the VCO divide count. All 16 frequency registers work with the same reference divide count, provided by the Fixed PLL Reference Divider register.

These 16 registers have a different format (M, N) when EXT/INT = 001 or 011.

**M0-M7, N0-N7**

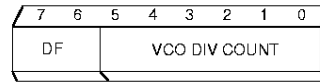

**Index:** 0x0020, 0x0022, 0x0024, 0x0026, 0x0028, 0x002A, 0x002C, 0x002E  
**Access:** Read/Write  
**Power on Value:** 0x00  
**Bits 7 - 6** DF - Desired Frequency  
**Bits 5 - 0** VCO DIV COUNT - VCO Divide Count

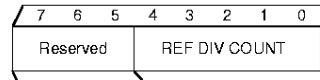

**Index:** 0x0021, 0x0023, 0x0025, 0x0027, 0x0029, 0x002B, 0x002D, 0x002F  
**Access:** Read/Write  
**Power on Value:** 0x00  
**Bits 7 - 5** Reserved  
**Bits 4 - 0** REF DIV COUNT - Reference Divide Count

The above diagrams show the formats for the 8 'M' and 8 'N' frequency registers. These formats are selected when the EXT/INT bits (PLL Control 1 Register, bits 2:0) = 001 or 011.

The 8 registers are grouped into four pairs, M0/N0, M1/N1, M2/N2, M3/N3. For a given pair, the "M" register provides the PLL with the DF value and the VCO divide count, and the "N" register provides the PLL with the reference divide count.

As described above these 16 registers have a different format (F) when EXT/INT = 000 or 010.

### 10.2.4 Cursor

#### Cursor Control

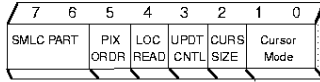

**Index:** 0x0030  
**Access:** Read/Write  
**Power on Value:** 0x00

**Bits 7 - 6** SMLC PART - Small Cursor Partition. Selects 1 of 4 partitions within the cursor array to use for the 32 x 32 cursor:

- 00 0x0100 - 0x01ff
- 01 0x0200 - 0x02ff
- 10 0x0300 - 0x03ff
- 11 0x0400 - 0x04ff

These bits have no effect when the cursor size is 64 x 64.

**Bit 5** PIX ORDR - Pixel Order. Specifies ordering of pixel bits in the bytes of the cursor array.

0 Right-to-left

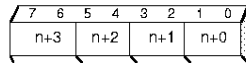

1 Left-to-right

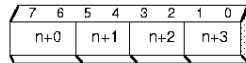

**Bit 4** LOC READ - Location Read-back Value. Specifies the value obtained by microprocessor reads of the Cursor X Low, Cursor X High, Cursor Y Low, and Cursor Y High registers.

- 0 Written Value - the value last written.
- 1 Actual Location - the location presently used for display. This will be different than the written value if a location register has been written but the location has not yet been updated. Following a cursor location update the "Written Value" and the "Actual Location" will be the same.

**Bit 3** UPDT CNTL - Cursor Location Update Control. Controls when Cursor Location registers are sampled to change the cursor position.

- 0 Delayed - A write to the Cursor Y High register arms the circuitry for the update. The position is then updated (the cursor moves to the new location) when a vertical blanking period is detected.
- 1 Immediate - Move the cursor immediately following a write to any of the Cursor X Low, Cursor X High, Cursor Y Low, or Cursor Y High registers.

**Bit 2** Cursor Size

- 0 32 x 32
- 1 64 x 64

**Bits 1 - 0** Cursor Mode

- 00 OFF
- 01 Mode 0 (3 colors)
- 10 Mode 1 (2 colors and highlighting)
- 11 Mode 2 (2 colors)

**Cursor X Low**

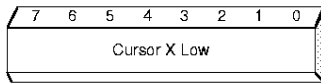

**Index:** 0x0031  
**Access:** Read/Write  
**Power on Value:** Undefined  
**Bits 7 - 0** Cursor X Low. The low order bits of the cursor X (horizontal) position.

A write to this register will update the cursor position:

1. When both the Cursor Y High register is written and vertical blanking is detected, OR
2. Immediately

under control of the UPDT CNTL bit of the Cursor Control register.

The value read back:

1. Written Value, or
2. Actual Location

is controlled by the LOC READ bit of the Cursor Control register:

**Cursor X High**

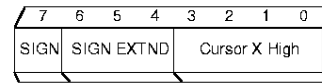

**Index:** 0x0032  
**Access:** Read/Write  
**Power on Value:** Undefined  
**Bit 7** Sign  
**Bits 6 - 4** SIGN EXTND - Sign Extended.

These bits are always the same as bit 7. On a write these bits are discarded and replaced with the value written to bit 7. On a read they will return the same value as bit 7.

**Bits 3 - 0** Cursor X High. The high order bits of the cursor X (horizontal) position.

Cursor X High and Cursor X Low form a combined register that holds a signed cursor X position in two's complement form. The X position range is -4096 to +4095.

A write to this register will update the cursor position:

1. When both the Cursor Y High register is written and vertical blanking is detected, OR
2. Immediately

under control of the UPDT CNTL bit of the Cursor Control register

The value read back:

1. Written Value, or
2. Actual Location

is controlled by the LOC READ bit of the Cursor Control register.

**Cursor Y Low**

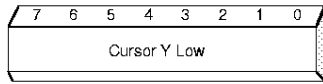

**Index:** 0x0033  
**Access:** Read/Write  
**Power on Value:** Undefined  
**Bits 7 - 0** Cursor Y Low. The low order bits of the cursor Y (vertical) position.

A write to this register will update the cursor position:

1. When both the Cursor Y High register is written and vertical blanking is detected, or
2. Immediately

under control of the UPDT CNTL bit of the Cursor Control register.

The value read back:

1. Written Value, or
2. Actual Location

is controlled by the LOC READ bit of the Cursor Control register.

**Cursor Y High**

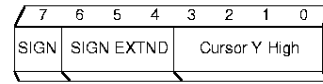

**Index:** 0x0034  
**Access:** Read/Write  
**Power on Value:** Undefined  
**Bit 7** Sign  
**Bits 6 - 4** SIGN EXTND - Sign Extended. These bits are always the same as bit 7. On a write these bits are discarded and replaced with the value written to bit 7. On a read they will return the same value as bit 7.  
**Bits 3 - 0** Cursor Y High. The high order bits of the cursor Y (vertical) position.

Cursor Y High and Cursor Y Low form a combined register that holds a signed cursor Y position in two's complement form. The Y position range is -4096 to +4095.

A write to this register will update the cursor position:

1. When vertical blanking is detected, or
2. Immediately

under control of the UPDT CNTL bit of the Cursor Control register.

The value read back:

1. Written Value, or
2. Actual Location

is controlled by the LOC READ bit of the Cursor Control register.

## Cursor Hot Spot X

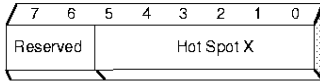
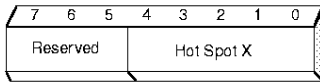

**Index:** 0x0035  
**Access:** Read/Write  
**Power on Value:** Undefined  
*32x32 Cursor*

**Bits 7 - 5** Reserved  
**Bits 4 - 0** HOT SPOT X. Specifies which pixel in a cursor row is the X position pixel.

*64x64 Cursor*

**Bits 7 - 6** Reserved  
**Bits 5 - 0** HOT SPOT X. Specifies which pixel in a cursor row is the X position pixel.

## Cursor Hot Spot Y

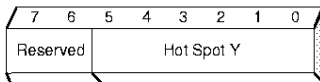
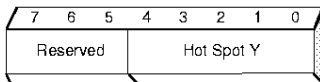

**Index:** 0x0036  
**Access:** Read/Write  
**Power on Value:** Undefined  
*32x32 Cursor*

**Bits 7 - 5** Reserved  
**Bits 4 - 0** HOT SPOT Y. Specifies which pixel in a cursor column is the Y position pixel.

*64x64 Cursor*

**Bits 7 - 6** Reserved  
**Bits 5 - 0** HOT SPOT Y. Specifies which pixel in a cursor column is the Y position pixel.

## Cursor Color 1 Red

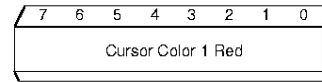

**Index:** 0x0040  
**Access:** Read/Write  
**Power on Value:** Undefined  
**Bits 7 - 0** Cursor Color 1 Red

## Cursor Color 1 Green

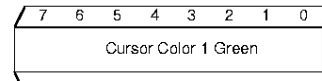

**Index:** 0x0041  
**Access:** Read/Write  
**Power on Value:** Undefined  
**Bits 7 - 0** Cursor Color 1 Green

## Cursor Color 1 Blue

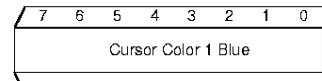

**Index:** 0x0042  
**Access:** Read/Write  
**Power on Value:** Undefined  
**Bits 7 - 0** Cursor Color 1 Blue

## Cursor Color 2 Red

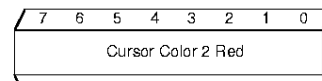

**Index:** 0x0043  
**Access:** Read/Write  
**Power on Value:** Undefined  
**Bits 7 - 0** Cursor Color 2 Red

## Cursor Color 2 Green

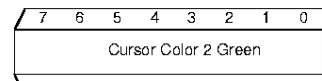

**Index:** 0x0044  
**Access:** Read/Write  
**Power on Value:** Undefined  
**Bits 7 - 0** Cursor Color 2 Green

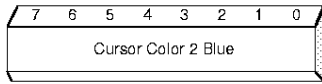
**Cursor Color 2 Blue**

**Index:** 0x0045  
**Access:** Read/Write  
**Power on Value:** Undefined  
**Bits 7 - 0** Cursor Color 2 Blue

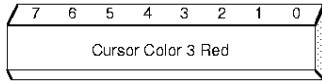
**Cursor Color 3 Red**

**Index:** 0x0046  
**Access:** Read/Write  
**Power on Value:** Undefined  
**Bits 7 - 0** Cursor Color 3 Red

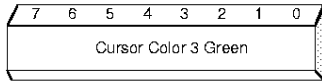
**Cursor Color 3 Green**

**Index:** 0x0047  
**Access:** Read/Write  
**Power on Value:** Undefined  
**Bits 7 - 0** Cursor Color 3 Green

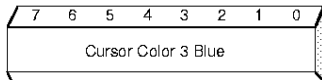
**Cursor Color 3 Blue**

**Index:** 0x0048  
**Access:** Read/Write  
**Power on Value:** Undefined  
**Bits 7 - 0** Cursor Color 3 Blue

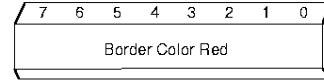
**10.2.5 Border Color**
**Border Color Red**

**Index:** 0x0060  
**Access:** Read/Write  
**Power on Value:** Undefined  
**Bits 7 - 0** Border Color Red

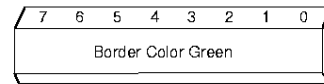
**Border Color Green**

**Index:** 0x0061  
**Access:** Read/Write  
**Power on Value:** Undefined  
**Bits 7 - 0** Border Color Green

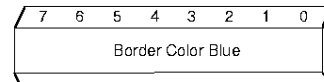
**Border Color Blue**

**Index:** 0x0062  
**Access:** Read/Write  
**Power on Value:** Undefined  
**Bits 7 - 0** Border Color Blue



### 10.2.6 Diagnostic Support

#### Revision Level

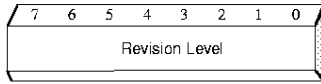

**Index:** 0x0000  
**Access:** Read Only  
**Power on Value:** Revision Level  
**Bits 7 - 0** Product Revision Level

The value in this register is 0xf0

#### ID

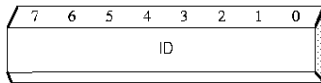

**Index:** 0x0001  
**Access:** Read Only  
**Power on Value:** 0x01  
**Bits 7 - 0** Product Identification Code

This register distinguishes among the various members of the IBM Microelectronics Palette DAC family. The value of 0x01 indicates that this is a member of the RGB525 compatible series.

#### DAC Sense

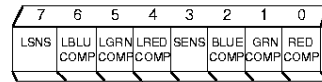

**Index:** 0x0082  
**Access:** Read Only  
**Power on Value:** Undefined  
**Bit 7** LSNS - Latched Sense  
**Bit 6** LBLU COMP - Latched Blue DAC Comparator Output  
**Bit 5** LGRN COMP - Latched Green DAC Comparator Output  
**Bit 4** LRED COMP - Latched Red DAC Comparator Output  
**Bit 3** SENS - Sense  
**Bit 2** BLU COMP - Blue DAC Comparator Output  
**Bit 1** GRN COMP - Green DAC Comparator Output  
**Bit 0** RED COMP - Red DAC Comparator Output

Bits 2,1,0 are the outputs of the three DAC reference comparators. The DAC output voltages are compared against the 0.35 V internal reference voltage (presented on COMPVREF). These bits are the "raw" outputs of the comparators.

Bits 6,5,4 are latched copies of bits 2,1,0. The latches are clocked during active line time (when BLANK and BORDER are both high).

Bit 3 (Sense) represents the combined status of bits 2,1,0. If any of these bits is 0, bit 3 will be 0.

Bit 7 (Latched Sense) represents the combined status of bits 6,5,4. If any of these bits is 0, bit 7 will be 0.

Either bit 3 or bit 7 will be presented on the SENSE output, depending on the SENS SEL bit of the Miscellaneous Control 1 register.

If the selected bit is 0, SENSE will be low.

If the selected bit is 1, SENSE will be high.

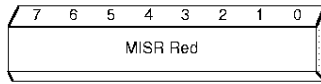
**MISR Red**

**Index:** 0x0084  
**Access:** Read Only  
**Power on Value:** Undefined  
**Bits 7 - 0** Multiple Input Signature Register Red

This register along with MISR GREEN and MISR BLUE is used to accumulate a diagnostic signature on the values presented to the DACs. The input to the Red DAC is the parallel data input to this portion of the MISR.

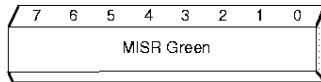
**MISR Green**

**Index:** 0x0086  
**Access:** Read Only  
**Power on Value:** Undefined  
**Bits 7 - 0** Multiple Input Signature Register Green

This register along with MISR RED and MISR BLUE is used to accumulate a diagnostic signature on the values presented to the DACs. The input to the Green DAC is the parallel data input to this portion of the MISR.

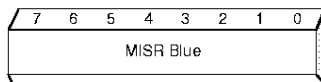
**MISR Blue**

**Index:** 0x0088  
**Access:** Read Only  
**Power on Value:** Undefined  
**Bits 7 - 0** Multiple Input Signature Register Blue

This register along with MISR RED and MISR GREEN is used to accumulate a diagnostic signature on the values presented to the DACs. The input to the Blue DAC is the parallel data input to this portion of the MISR.

**Note:** The reset, accumulation, and hold function of the MISR is controlled by the MISR CNTL bit of the Miscellaneous Control 1 register, and the BLANK input. See 8.6, "Diagnostic Support," on page 22 for more information.

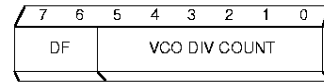
**PLL VCO Divider Input**

**Index:** 0x008e  
**Access:** Read Only  
**Power on Value:** 0x00  
**Bits 7 - 6** DF - Desired Frequency  
**Bits 5 - 0** VCO DIV COUNT - VCO Divide Count

This register allows readback of the selected PLL VCO divider input. It is one of these registers:

- F0, F1, F2, F3, F4, F5, F6, F7, F8, F9, F10, F11, F12, F13, F14, F15
- M0, M1, M2, M3, M4, M5, M6, M7

as determined by the PLL Control 1 EXT/INT bits (2:0), the inputs FS[3:0], and PLL Control 2 INT FS bits (3:0).

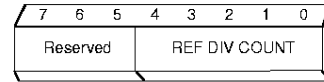
**PLL Reference Divider Input**

**Index:** 0x008f  
**Access:** Read Only  
**Power on Value:** Undefined  
**Bits 7 - 5** Reserved  
**Bits 4 - 0** REF DIV COUNT - Reference Divide Count

This register allows readback of the input to the PLL reference divider.

- Fixed PLL Reference Divider
- N0, N1, N2, N3, N4, N5, N6, N7

as determined by the PLL Control 1 EXT/INT bits (2:0), the inputs FS[3:0], and PLL Control 2 INT FS bits (3:0).

## VRAM Mask Low

7	6	5	4	3	2	1	0
MASK	MASK	MASK	MASK	MASK	MASK	MASK	MASK
31:28	27:24	23:20	19:16	15:12	11:08	07:04	03:00

- Index:** 0x0090  
**Access:** Read/Write  
**Power on Value:** Undefined
- Bit 7** Mask VRAM PIX inputs 31:28
  - Bit 6** Mask VRAM PIX inputs 27:24
  - Bit 5** Mask VRAM PIX inputs 23:20
  - Bit 4** Mask VRAM PIX inputs 19:16
  - Bit 3** Mask VRAM PIX inputs 15:12
  - Bit 2** Mask VRAM PIX inputs 11:08
  - Bit 1** Mask VRAM PIX inputs 07:04
  - Bit 0** Mask VRAM PIX inputs 03:00

A value of 1 on any of the bits in this register masks (forces to 0) the corresponding received VRAM pixel port inputs. This register has no effect on the inputs unless enabled with the VMSK CNTL bit of the Miscellaneous Control 1 register.

## VRAM Mask High

7	6	5	4	3	2	1	0
MASK	MASK	MASK	MASK	MASK	MASK	MASK	MASK
63:60	59:56	55:52	51:48	47:44	43:40	39:36	35:32

- Index:** 0x0091  
**Access:** Read/Write  
**Power on Value:** Undefined
- Bit 7** Mask VRAM PIX inputs 63:60
  - Bit 6** Mask VRAM PIX inputs 59:56
  - Bit 5** Mask VRAM PIX inputs 55:52
  - Bit 4** Mask VRAM PIX inputs 51:48
  - Bit 3** Mask VRAM PIX inputs 47:44
  - Bit 2** Mask VRAM PIX inputs 43:40
  - Bit 1** Mask VRAM PIX inputs 39:36
  - Bit 0** Mask VRAM PIX inputs 35:32

A value of 1 on any of the bits in this register masks (forces to 0) the corresponding received VRAM pixel port inputs. This register has no effect on the inputs unless enabled with the VMSK CNTL bit of the Miscellaneous Control 1 register.

**Note:** The mask function is intended to be used with the MISR for diagnostics. See § 6, "Diagnostic Support," on page 28 for more details.

## 11.0 Pin Descriptions

**Table 10. Pin Descriptions**

Signal	Type	Pin(s)	Description
<b>Clocks and Clock Controls</b>			
REFCLK	I	121	Reference Clock. A fixed frequency of 2 MHz to 100 MHz applied to this pin provides the reference clock for the programmable PLL. When the Direct Programming method is used the REFCLK frequency range is 4 MHz to 62 MHz on 2 MHz boundaries.
EXTCLK	I	122	External Clock. An alternate source of REFCLK or the pixel clock. Generally intended for laboratory bringup, it may also be used functionally. However, the maximum frequency rating of 100 MHz may limit its usefulness as the pixel clock.
FS[3:0]	I	172, 171, 166, 165	Frequency Select. These 4 inputs select one of 16 sets of registers containing the programming values for PLL.
DDOTCLK	O	158	Divided Dot Clock. The output of the PLL, divided by 1, 2, 4, 8 or 16. The divide factor is under register control. In 24 BPP Packed pixel mode the SCLK signal can be selected for this output instead of the divided PLL output, under register control. This output can be 3-stated under register control.
SCLK	O	153	Serial Clock. A divided version of the PLL, where the divide ratio is determined by the required bandwidth of the incoming pixels. When the PIX port is selected, the SCLK frequency is a function of the VRAM width and the pixel format (bits per pixel). SCLK is equal to the PLL output when the VGA port is selected. This output can be 3-stated under register control.
LCLK	I	145	Load Clock. Latches data from the PIX port, the VGA port, and the video control inputs.
<b>Video Data Inputs</b>			
PIX[63:0]	I	164, 163, 162, 161, 160, 159, 201, 152, 151, 150, 149, 148, 147, 146, 200, 144, 203, 202, 199, 198, 193, 118, 115, 114, 113, 112, 111, 103, 102, 101, 100, 99, 98, 97, 96, 95, 94, 91, 90, 89, 88, 87, 86, 85, 84, 83, 82, 81, 80, 78, 77, 76, 75, 74, 73, 72, 71, 70, 69, 68, 67, 64, 63, 62	Pixel data in from VRAMs. Pixel data in can be selected as 64 or 32 bits using the VRAM SIZE bit of the Miscellaneous Control 1 register. For 32-bit use inputs PIX[63:32] are not used. Latched on rising edge of LCLK.
VGA[7:0]	I	61, 60, 59, 58, 57, 56, 55, 54	VGA data in. Latched on rising edge of LCLK.
Type: I = Input, O = Output, B = Bidirectional, C = Component			

Table 10. Pin Descriptions (Continued)

Signal	Type	Pin(s)	Description
<b>Video Control Inputs</b>			
$\overline{\text{BLANK}}$	I	116	A low level indicates blanking time; a high level indicates active picture time (pixel data, cursor, or border displayed). Latched on rising edge of LCLK.
$\overline{\text{BORDER}}$	I	117	When $\overline{\text{BLANK}}$ is high (picture time), a low level on $\overline{\text{BORDER}}$ indicates the contents of the border registers should be displayed, and a high level indicates that pixel data or cursor should be displayed. When $\overline{\text{BLANK}}$ is low (blanking time) $\overline{\text{BORDER}}$ must be low. If no border is to be displayed $\overline{\text{BORDER}}$ should be tied to $\overline{\text{BLANK}}$ . Latched on rising edge of LCLK.
$\overline{\text{HSYNCIN}}$	I	104	Horizontal Sync In. A delayed copy of this signal is presented on $\overline{\text{HSYNCOUT}}$ to align the timing of horizontal sync to the pixel data at the DACs. The incoming polarity can be inverted under register control. Latched on rising edge of LCLK.
$\overline{\text{VSYNCIN}}$	I	109	Vertical Sync In. A copy of this signal is presented on $\overline{\text{VSYNCOUT}}$ . The incoming polarity can be inverted under register control.
$\overline{\text{CSYNCIN}}$	I	110	Composite Sync In. When enabled, this signal is presented on the Green DAC with the video data. The signal is delayed to match the delay of the pixel data. The incoming polarity can be inverted under register control. Latched on rising edge of LCLK
<b>Video Control Outputs</b>			
$\overline{\text{HSYNCOUT}}$	O	47	Horizontal Sync Out. This is a copy of $\overline{\text{HSYNCIN}}$ (or inverted $\overline{\text{HSYNCIN}}$ ), delayed by the same number of pixel clocks as seen by the pixel data at the input to the DACs. It can be forced to a high or low level or 3-stated under register control. The amount of delay may also be adjusted with the Horizontal Sync Position register.
$\overline{\text{VSYNCOUT}}$	O	48	Vertical Sync Out. This is a copy of $\overline{\text{VSYNCIN}}$ (or inverted $\overline{\text{VSYNCIN}}$ ). It can be forced to a high or low level or 3-stated under register control.
<b>Microprocessor Interface</b>			
$\overline{\text{WR}}$	I	186	Write strobe. Writes data into the register selected by RS[2:0]. The leading edge samples RS[2:0]. The trailing edge clocks the data on D[7:0] into the selected register.
$\overline{\text{RD}}$	I	187	Read strobe. Drives the register contents selected by RS[2:0] onto D[7:0]. The leading edge samples RS[2:0]. When $\overline{\text{RD}}$ is low the D[7:0] drivers are enabled.
RS[2:0]	I	180, 179, 177	Register selects. Sampled on the leading edge of $\overline{\text{WR}}$ and $\overline{\text{RD}}$ and used to select one of the direct access registers. See Direct Access Registers for more details.
D[7:0]	B	182, 181, 178, 176, 175, 174, 173, 168	Bidirectional data bus for internal register write and read data. The drivers are enabled when $\overline{\text{RD}}$ is low, otherwise they are 3-stated.
Type: I = Input, O = Output, B = Bidirectional, C = Component			

**Table 10. Pin Descriptions (Continued)**

Signal	Type	Pin(s)	Description
<b>Miscellaneous</b>			
$\overline{\text{RESET}}$	I	189	Internal register and PLL reset. Resets bits of certain registers to a given state. (Generally set to VGA operation. See register descriptions for details.) Also initializes PLL circuits. A reset is <b>required</b> following power on to guarantee proper PLL operation.
$\overline{\text{ODD/EVEN}}$	I	13	Used in interlace mode to identify a field as odd or even; determines which row of cursor RAM to display if the cursor is enabled. This input should only change during vertical blanking.
$\overline{\text{SENSE}}$	O	167	DAC sense comparator output. Goes low when one or more of the three DAC outputs is above the comparator voltage reference. The three individual comparator outputs are also available as register bits. Either unlatched or latched comparator outputs may be selected for generating the $\overline{\text{SENSE}}$ output, under register control. This output can be 3-stated under register control.
<b>Video Outputs</b>			
RED	O	30	Plus RED video out.
$\overline{\text{RED}}$	O	33	Minus RED video out.
GREEN	O	40	Plus GREEN video out.
$\overline{\text{GREEN}}$	O	41	Minus GREEN video out.
BLUE	O	45	Plus BLUE video out.
$\overline{\text{BLUE}}$	O	44	Minus BLUE video out.
Type: I = Input, O = Output, B = Bidirectional, C = Component			

Table 10. Pin Descriptions (Continued)

Signal	Type	Pin(s)	Description
<b>DAC Support</b>			
VREFIN	C	28	Voltage Reference In for the DACs. Connect 1.235 V to this pin and decouple it with a 10 nF ceramic capacitor to DACGND.
RREF	C	37	Resistor Reference. Connect a resistor from this pin to DACGND. This pin connects to an internal op amp which compares the voltage on this pin to that of VREFIN, and adjusts the current flowing out of the RREF pin such that the voltage developed across the reference resistor matches VREFIN. The value of the resistor determines the full scale output current of the DACs. A value of 698 $\Omega$ is recommended.
CVREF	C	25	Comparator Voltage Reference. An internal voltage divider between VREFIN and DACGND sets this pin to 0.35V. It is used internally by comparators to sense the values of the DAC outputs. Decouple this pin to DACGND with a 1nF ceramic capacitor.
GREF	C	24	DAC Gate Reference. Output of DAC op amp and input to gates of devices connecting DACVDD to the DAC current switches. Decouple this pin to DACVDD with a 1 nF ceramic capacitor.
<b>PLL Support</b>			
RPLLI	C	127	PLL Resistor 1. Connect this pin to PLLVDD by a 8.66 K $\Omega$ resistor. This sets the charge pump current to the PLL.
REXT	C	131	PLL Resistor 2. Connect this pin to PLLGND by a 10 K $\Omega$ resistor. This sets the VCO gain of the PLL.
RCI	C	130	Loop filter. Connect to parallel 1.3 K $\Omega$ resistor and 680 pF capacitor. Return parallel resistor and capacitor to RCRET through 8.2 nF capacitor.
RCRET	C	129	Loop filter return. Connect as described above under RCI.
Type: I = Input, O = Output, B = Bidirectional, C = Component			

**Table 10. Pin Descriptions (Continued)**

Signal	Type	Pin(s)	Description
<b>Manufacturing Test</b>			
$\overline{\text{TESTMODE}}$	I	194	This input must be high for functional use.
RMUXCTL	I	204	This input must be low for functional use.
DMUXCTL	I	195	This input must be low for functional use.
$\overline{\text{DI1}}$	I	12	This input must be high for functional use.
$\overline{\text{DI2}}$	I	6	This input must be high for functional use.
$\overline{\text{RI}}$	I	208	This input must be high for functional use. An external 1 K $\Omega$ resistor to VDD is recommended.
<b>Power and Ground</b>			
VDD		1, 4, 16, 38, 50, 53, 66, 92, 105, 108, 120, 142, 154, 157, 170, 196	Logic Power (3.3 V)
GND		2, 3, 15, 27, 39, 51, 52, 65, 79, 93, 106, 107, 119, 123, 124, 136, 137, 143, 155, 156, 169, 183, 197	Logic Ground
DACVDD		23, 29, 31, 35, 42, 46	DAC Power (3.3 V)
DACGND		26, 32, 34, 36, 43	DAC Ground
PLLVDD		128	PLL Power (3.3 V)
PLLGND		132	PLL Ground
<b>Unused</b>			
NC		5, 7, 8, 9, 10, 11, 14, 17, 18, 19, 20, 21, 22, 49, 125, 126, 133, 134, 135, 138, 139, 140, 141, 184, 185, 188, 190, 191, 192, 205, 206, 207	No Connect. These pins must be left unconnected.
Type: I = Input, O = Output, B = Bidirectional, C = Component			



**Table 11. Signal List by Pin Number**

Pin	Signal	Description	Pin	Signal	Description	Pin	Signal	Description	Pin	Signal	Description
001	VDD	Logic Power (+3.3 V)	053	VDD	Logic Power (+3.3 V)	105	VDD	Logic Power (+3.3 V)	157	VDD	Logic Power (+3.3 V)
002	GND	Logic Ground	054	VGA[0]	VGA Data In	106	GND	Logic Ground	158	DDOTCLK	Divided Dot Clock Out
003	GND	Logic Ground	055	VGA[1]	VGA Data In	107	GND	Logic Ground	159	PIX[58]	Pixel Data In
004	VDD	Logic Power (+3.3 V)	056	VGA[2]	VGA Data In	108	VDD	Logic Power (+3.3 V)	160	PIX[59]	Pixel Data In
005	NC	No Connect	057	VGA[3]	VGA Data In	109	VSYNCIN	Vertical Sync In	161	PIX[60]	Pixel Data In
006	DI2	Driver Inhibit 2 (Test)	058	VGA[4]	VGA Data In	110	CSYNCIN	Composite Sync In	162	PIX[61]	Pixel Data In
007	NC	No Connect	059	VGA[5]	VGA Data In	111	PIX[37]	Pixel Data In	163	PIX[62]	Pixel Data In
008	NC	No Connect	060	VGA[6]	VGA Data In	112	PIX[38]	Pixel Data In	164	PIX[63]	Pixel Data In
009	NC	No Connect	061	VGA[7]	VGA Data In	113	PIX[39]	Pixel Data In	165	FS[0]	Frequency Select
010	NC	No Connect	062	PIX[00]	Pixel Data In	114	PIX[40]	Pixel Data In	166	FS[1]	Frequency Select
011	NC	No Connect	063	PIX[01]	Pixel Data In	115	PIX[41]	Pixel Data In	167	SENSE	DAC Sense
012	DI1	Driver Inhibit 1 (Test)	064	PIX[02]	Pixel Data In	116	BLANK	Blank In	168	D[0]	Microprocessor Data
013	ODD/EVEN	Interface Control	065	GND	Logic Ground	117	BORDER	Border In	169	GND	Logic Ground
014	NC	No Connect	066	VDD	Logic Power (+3.3 V)	118	PIX[42]	Pixel Data In	170	VDD	Logic Power (+3.3 V)
015	GND	Logic Ground	067	PIX[03]	Pixel Data In	119	GND	Logic Ground	171	FS[2]	Frequency Select
016	VDD	Logic Power (+3.3 V)	068	PIX[04]	Pixel Data In	120	VDD	Logic Power (+3.3 V)	172	FS[3]	Frequency Select
017	NC	No Connect	069	PIX[05]	Pixel Data In	121	REFCLK	PLL Ref Clock In	173	D[1]	Microprocessor Data
018	NC	No Connect	070	PIX[06]	Pixel Data In	122	EXTCLK	External Clock In	174	D[2]	Microprocessor Data
019	NC	No Connect	071	PIX[07]	Pixel Data In	123	GND	Logic Ground	175	D[3]	Microprocessor Data
020	NC	No Connect	072	PIX[08]	Pixel Data In	124	GND	Logic Ground	176	D[4]	Microprocessor Data
021	NC	No Connect	073	PIX[09]	Pixel Data In	125	NC	No Connect	177	RS[0]	Register Select [0]
022	NC	No Connect	074	PIX[10]	Pixel Data In	126	NC	No Connect	178	D[5]	Microprocessor Data
023	DACVDD	DAC Power (+3.3V)	075	PIX[11]	Pixel Data In	127	RPLLI	PLL Resistor 1	179	RS[1]	Register Select [1]
024	GREF	DAC Gate Ref	076	PIX[12]	Pixel Data In	128	PLLVD	PLL Power (+3.3V)	180	RS[2]	Register Select [2]
025	CVREF	DAC Comp. VREF	077	PIX[13]	Pixel Data In	129	RCRET	Loop Filter Return	181	D[6]	Microprocessor Data
026	DACGND	DAC Ground	078	PIX[14]	Pixel Data In	130	RCI	Loop Filter	182	D[7]	Microprocessor Data
027	GND	Logic Ground	079	GND	Logic Ground	131	REXT	PLL Resistor 2	183	GND	Logic Ground
028	VREFIN	DAC Voltage Ref	080	PIX[15]	Pixel Data In	132	PLLGND	PLL Ground	184	NC	No Connect
029	DACVDD	DAC Power (+3.3V)	081	PIX[16]	Pixel Data In	133	NC	No Connect	185	NC	No Connect
030	RED	+ Red Output	082	PIX[17]	Pixel Data In	134	NC	No Connect	186	WR	Microprocessor Write
031	DACVDD	DAC Power (+3.3V)	083	PIX[18]	Pixel Data In	135	NC	No Connect	187	RD	Microprocessor Read
032	DACGND	DAC Ground	084	PIX[19]	Pixel Data In	136	GND	Logic Ground	188	NC	No Connect
033	RED	- Red Output	085	PIX[20]	Pixel Data In	137	GND	Logic Ground	189	RESET	Reset
034	DACGND	DAC Ground	086	PIX[21]	Pixel Data In	138	NC	No Connect	190	NC	No Connect
035	DACVDD	DAC Power (+3.3V)	087	PIX[22]	Pixel Data In	139	NC	No Connect	191	NC	No Connect
036	DACGND	DAC Ground	088	PIX[23]	Pixel Data In	140	NC	No Connect	192	NC	No Connect
037	RREF	DAC Resistor Ref	089	PIX[24]	Pixel Data In	141	NC	No Connect	193	PIX[43]	Pixel Data In
038	VDD	Logic Power (+3.3 V)	090	PIX[25]	Pixel Data In	142	VDD	Logic Power (+3.3 V)	194	TESTMODE	Test Mode (Test)
039	GND	Logic Ground	091	PIX[26]	Pixel Data In	143	GND	Logic Ground	195	DMUXCTL	MUX Control (Test)
040	GREEN	+ Green Output	092	VDD	Logic Power (+3.3 V)	144	PIX[48]	Pixel Data In	196	VDD	Logic Power (+3.3 V)
041	GREEN	- Green Output	093	GND	Logic Ground	145	LCLK	Load Clock In	197	GND	Logic Ground
042	DACVDD	DAC Power (+3.3V)	094	PIX[27]	Pixel Data In	146	PIX[50]	Pixel Data In	198	PIX[44]	Pixel Data In
043	DACGND	DAC Ground	095	PIX[28]	Pixel Data In	147	PIX[51]	Pixel Data In	199	PIX[45]	Pixel Data In
044	BLUE	- Blue Output	096	PIX[29]	Pixel Data In	148	PIX[52]	Pixel Data In	200	PIX[49]	Pixel Data In
045	BLUE	+ Blue Output	097	PIX[30]	Pixel Data In	149	PIX[53]	Pixel Data In	201	PIX[57]	Pixel Data In
046	DACVDD	DAC Power (+3.3V)	098	PIX[31]	Pixel Data In	150	PIX[54]	Pixel Data In	202	PIX[46]	Pixel Data In
047	HSYNCOUT	Horizontal Sync Out	099	PIX[32]	Pixel Data In	151	PIX[55]	Pixel Data In	203	PIX[47]	Pixel Data In
048	VSYNCOUT	Vertical Sync Out	100	PIX[33]	Pixel Data In	152	PIX[56]	Pixel Data In	204	RMUXCTL	MUX Control (Test)
049	NC	No Connect	101	PIX[34]	Pixel Data In	153	SCLK	Serial Clock Out	205	NC	No Connect
050	VDD	Logic Power (+3.3 V)	102	PIX[35]	Pixel Data In	154	VDD	Logic Power (+3.3 V)	206	NC	No Connect
051	GND	Logic Ground	103	PIX[36]	Pixel Data In	155	GND	Logic Ground	207	NC	No Connect
052	GND	Logic Ground	104	HSYNCIN	Horizontal Sync In	156	GND	Logic Ground	208	RI	Receiver Inhibit (Test)

## 12.0 Electrical and Timing Specifications

**Table 12. Recommended Operating Conditions**

Parameter	Symbol	170 MHz		220 MHz		250 MHz		250 MHz		Units
		Min.	Max.	Min.	Max.	Min.	Max.	Min.	Max.	
Power Supply	VDD, DACVDD, PLLVDD	3.0	3.6	3.0	3.6	3.0	3.6	3.14	3.6	Volts
Case Temperature	T <sub>C</sub>	0	100	0	100	0	85	0	100	°C
DAC Output Load	R <sub>L</sub>	37.5	50	37.5	50	37.5	50	37.5	50	Ω
Reference Voltage	V <sub>REF</sub>	1.204	1.266	1.204	1.266	1.204	1.266	1.204	1.266	Volts

**Table 13. Absolute Maximum Ratings**

Parameter	Symbol	Min.	Max.	Units
Power Supply	VDD, DACVDD, PLLVDD	-0.5	3.8	Volts
Signal Pin Voltage		-0.5	5.5	Volts
DAC Output Short Circuit Duration	t <sub>sc</sub>		∞	seconds
Case Temperature	T <sub>C</sub>	0	145	°C
Soldering Temperature (5 seconds, 0.25 in. from case)	T <sub>SOL</sub>		260	°C
Vapor Phase Soldering Temperature (1 minute)	T <sub>V,SOL</sub>		220	°C

**Table 14. DC Characteristics**

Parameter	Symbol	Min.	Typical	Max.	Units
<b>DAC Outputs</b>					
Resolution		8	8	8	Bits
Integral Linearity Error	ILE			3/4	LSB
Differential Linearity Error	DLE			3/4	LSB
Grey Scale Error				5	% Grey Scale
Monotonicity		Guaranteed	Guaranteed	Guaranteed	
Coding					Binary
<b>CMOS Digital Inputs</b>					
Input High Voltage (V <sub>DD</sub> = 3.3 V)	V <sub>IH</sub>	2.0		5.5	Volts
Input Low Voltage	V <sub>IL</sub>	-0.5		0.8	Volts
Input High Current (V <sub>IH</sub> = 2.4V)	I <sub>IH</sub>			20	μA
Input Low Current (V <sub>IL</sub> = 0.0V)	I <sub>IL</sub>	-20			μA
Input Capacitance (f=1 MHz, V <sub>IN</sub> = 2.4V)	C <sub>IN</sub>		4	8	pF
<b>Digital Outputs</b>					
Output High Voltage (I <sub>OH</sub> = -12 mA)	V <sub>OH</sub>	2.4			Volts
Output Low Voltage (I <sub>OL</sub> = 6 mA)	V <sub>OL</sub>			0.4	Volts
Hi-Z Current (0 ≤ V ≤ 3.6 V)	I <sub>OZ</sub>	-20		20	μA
<b>Analog Outputs</b>					
DAC Inaccuracy				7	%
DAC-to-DAC Mismatch				5	%
Output Compliance	V <sub>OC</sub>	-0.5		1.2	Volts

Table 15. AC Characteristics

Parameter	Symbol	Spec.	170 MHz	220 MHz	250 MHz	Units
RS[2:0] Setup	t <sub>1</sub>	min	10	10	10	ns
RS[2:0] Hold	t <sub>2</sub>	min	10	10	10	ns
RD, WR Low	t <sub>3</sub>	min	50	50	50	ns
RD, WR High	t <sub>4</sub>	min	6 × pelk	6 × pelk	6 × pelk	ns
RD Low to Data Bus Driven	t <sub>5</sub>	min	2	2	2	ns
RD Low to Data Bus Valid	t <sub>6</sub>	max	40	40	40	ns
RD High to Data Bus 3-Stated	t <sub>7</sub>	max	20	20	20	ns
Data Bus Hold from RD High	t <sub>8</sub>	min	2	2	2	ns
Write Data Setup	t <sub>9</sub>	min	10	10	10	ns
Write Data Hold	t <sub>10</sub>	min	10	10	10	ns
LCLK, SCLK Low	t <sub>11</sub>	min	4	4	4	ns
LCLK, SCLK High	t <sub>12</sub>	min	4	4	4	ns
LCLK, SCLK Cycle	t <sub>13</sub>					
16:1 MUX Mode		max	10.6	13.75	15.63	MHz
8:1 MUX Mode		max	21.25	27.5	31.25	MHz
4:1 MUX Mode		max	42.5	55	62.5	MHz
2:1 MUX Mode		max	85	100	100	MHz
1:1 MUX Mode		max	100	100	100	MHz
16:1 MUX Mode		min	94.12	72.7	64	ns
8:1 MUX Mode		min	47.06	36.4	32	ns
4:1 MUX Mode		min	23.53	18.2	16	ns
2:1 MUX Mode		min	11.77	10	10	ns
1:1 MUX Mode		min	10	10	10	ns
PIX[63:0] Setup	t <sub>14</sub>	min	1	1	1	ns
PIX[63:0] Hold	t <sub>15</sub>					
1:1 MUX Mode		min	4	4	4	ns
Not 1:1 MUX Mode		min	2	2	2	ns
VGA[7:0], BLANK, BORDER HSYNCIN, CSYNCIN Setup	t <sub>16</sub>	min	3	3	3	ns
VGA[7:0], BLANK, BORDER HSYNCIN, CSYNCIN Hold	t <sub>17</sub>	min	3	3	3	ns
SCLK to LCLK skew (T=SCLK cycle time)	t <sub>18</sub>	min max	-2 T-8	-2 T-8	-2 T-8	ns ns
Supply Current (1)		typ(2) max(3)	450 716	650 890	660 1000	mA mA

Notes:

- Supply current is the total of I<sub>VDD</sub>, I<sub>VDDDAC</sub> and I<sub>VDDPLL</sub>.
- Typical power dissipation is for VDD, VDDDAC, VDDPLL = 3.3 V, TA = 20 °C, with typical pixel patterns such as displayed with graphical user interfaces, and  
 170 MHz part running at 135 MHz (e.g., for 1280 x 1024 screen)  
 220 MHz part running at 216 MHz (e.g., for 1600 x 1280 screen)  
 250 MHz part running at 220 MHz
- Maximum power dissipation is for VDD, VDDDAC, VDDPLL = 3.6 V, TA = 0 °C, with alternating full black/full white pixels running at the maximum specified frequency (170/220/250 MHz).

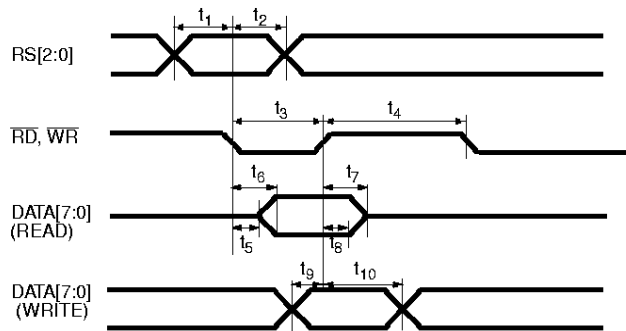

Figure 3. Microprocessor Interface Timing

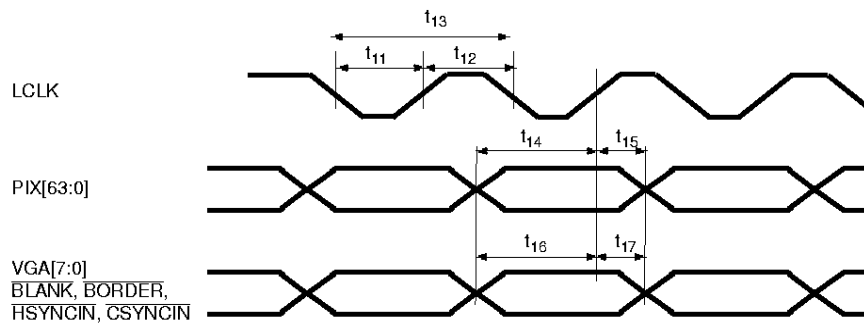

Figure 4. Pixel Data and Video Control Interface Timing

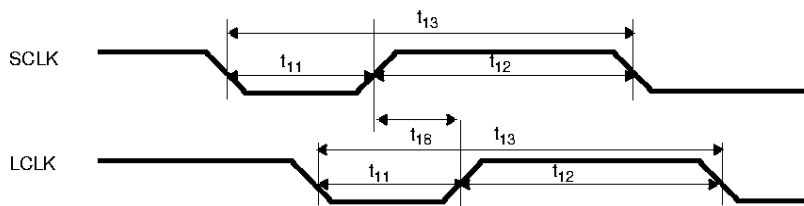

Figure 5. SCLK and LCLK Timing

13.0 Video Waveforms

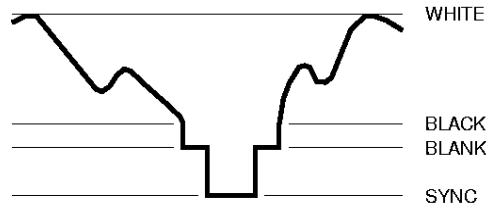

Table 16. Composite Video Output Waveform

Doubly terminated 75 ohms, RREF=698 ohms															
Sync	No			No			Yes			Yes					
Pedestal	No			Yes			No			Yes					
Value	IRE	mA	V	IRE	mA	V	IRE	mA	V	IRE	mA	V			
WHITE	100	18.65	0.70	92.5	19.05	0.714	100	26.67	1.00	92.5	26.67	1.00			
BLACK		0	0		7.5	1.43		0.054	8.02		0.30	7.5	9.05	0.339	
BLANK						0		0						7.62	0.286
SYNC									-30				-40	0	0

Note: RS-343A levels and tolerances assumed on all levels.

Table 17. Composite Video Output Waveform

Doubly terminated 100 ohms, RREF=927 ohms															
Sync	No			No			Yes			Yes					
Pedestal	No			Yes			No			Yes					
Value	IRE	mA	V	IRE	mA	V	IRE	mA	V	IRE	mA	V			
WHITE	100	13.99	0.70	92.5	14.28	0.714	100	20.00	1.00	92.5	20.00	1.00			
BLACK		0	0		7.5	1.07		0.054	6.01		0.30	7.5	6.78	0.339	
BLANK						0		0						5.71	0.286
SYNC									-30				-40	0	0

Note: RS-343A levels and tolerances assumed on all levels.

14.0 Package Information

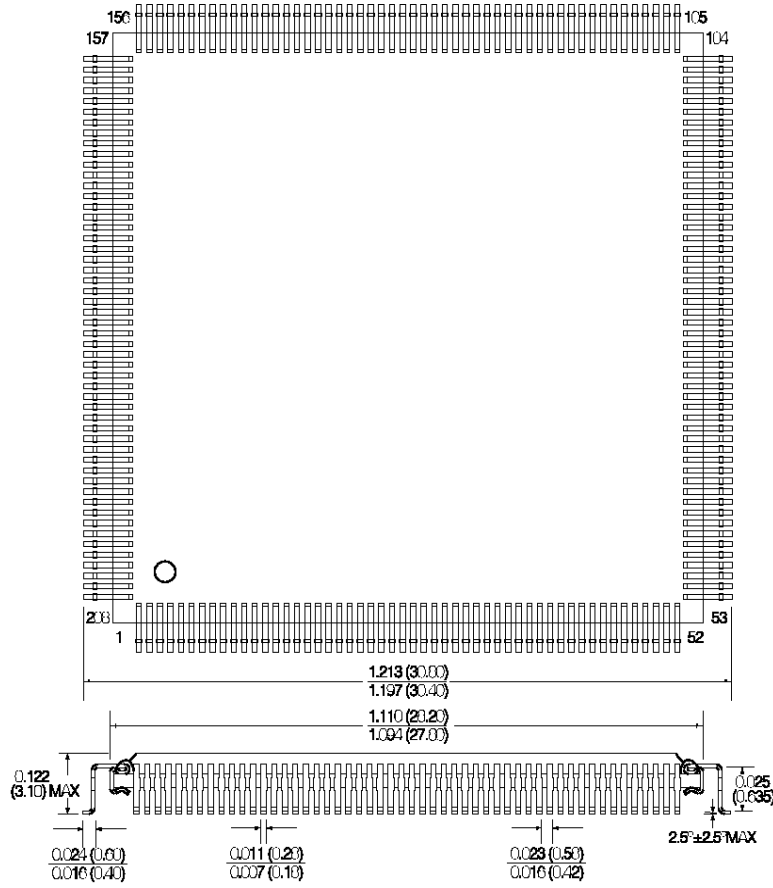

15.0 Ordering Information

Table 18. Part Numbers

Part Number	Speed
IBM37-RGB525L-17CC	170 MHz
IBM37-RGB525L-22CC	220 MHz
IBM37-RGB525L-25CC (*)	250 MHz

\* Quantities of IBM37-RGB525L-25CC will be limited until 3Q94.

## 16.0 Change Summary

**Table 19. Summary of Changes**

Date	Changes
9/93	1. First publication, PRELIMINARY information prior to product build.
3/94	<ol style="list-style-type: none"> <li>1. Moved/Changed some pin assignments to minimize chance of coupling from card wiring to PLL support components. Pins affected are: 013, 123-129, 131-141, 145, 153, 158, 193, 198-203. The signal and pin assignments are given in 11.6, "Pin Descriptions."</li> <li>2. A new speed rating of 220 MHz was added.</li> <li>3. Section 2.0, "Clocking," is changed to describe a second way of programming the pixel PLL. In addition to the original "direct programming" method, there is now an "M over N" method.</li> <li>4. Description is added for bits 2-0 of PLL Control 1 register and bits 3-0 of PLL Control 2 register to indicate controls for configuring the F0-F15 registers as M/N pairs for use with "M over N" programming of the PLL. These new bit combinations were previously reserved.</li> <li>5. The DAC slew rate is changed from 2.5 ns to 2.0 ns (typical), for the fast rate, and from 7.5 ns to 14 ns (typical). (The DAC slew rate is controlled by bit 1 of the DAC operation register.)</li> <li>6. The following errors concerning register operation were corrected: <ol style="list-style-type: none"> <li>a. In 7.6, "Power Management," the Miscellaneous Control Register was identified as index 0x0000. It is actually 0x0070.</li> <li>b. In 8.3, "MISR," the MISR control bit was identified as Miscellaneous Control Register bit 6. It is actually bit 7.</li> <li>c. The illustration of the DAC Operation Register incorrectly labeled bit 1 as "DAC". It is the "DSR" bit (DAC Slew Rate).</li> <li>d. In 10.2.6, "Diagnostic Support," the DAC Sense register was labeled as "Read/Write". It is actually "Read Only".</li> </ol> </li> <li>7. In Table 13, "Recommended Operating Conditions," the specification for ambient operating temperature is deleted. The case temperature specification is relaxed to 100°C for the 170 MHz and 220 MHz parts. The maximum case temperature stays at 85°C for the 250 MHz part, but can be relaxed to 100°C if the supply voltage is constrained to ± 5%.</li> <li>8. In Table 13, "Absolute Maximum Ratings," the specification for ambient operating temperature is deleted. The case temperature specification is relaxed to 145°C.</li> <li>9. In Table 14, "DC Characteristics," for DAC Outputs the Integral Linearity Error and Differential Linearity Error are each changed from 1/2 to 3/4 LSB.</li> <li>10. Also in Table 14, "DC Characteristics," for the Digital Output voltage levels the specified current draw is changed. I<sub>OH</sub> changes from 24 mA to -12 mA for V<sub>OH</sub>, and I<sub>OL</sub> changes from -10 mA to 6 mA for V<sub>OL</sub>.</li> <li>11. In Table 15, "AC Characteristics," the maximum LCLK,SCLK frequency for 16:1 MUX mode is changed from 10.06 MHz to 10.6 MHz for the 170 MHz part. Also for the 170 MHz part the minimum LCLK,SCLK cycle t<sub>13</sub> for 16:1 MUX mode is changed from 99.38 MHz to 94.12 MHz.</li> <li>12. Also in Table 15, "AC Characteristics," PIX[63:0] Hold time t<sub>15</sub> is relaxed from 5 ns, depending on the MUX mode. In 1:1 MUX mode the hold time is 4 ns; in non-1:1 MUX mode the hold time is 2 ns.</li> <li>13. Figure 5, "SCLK and LCLK Timing," is corrected to change the definition of t<sub>18</sub>, SCLK to LCLK skew. In Table 15, "AC Characteristics," t<sub>18</sub> is relaxed from 0 ns to -2 ns.</li> </ol>

**Table 19. Summary of Changes (Continued)**

Date	Changes
	<p>14. A supply current section, typical and max, is added to Table 15, "AC Characteristics."</p> <p>15. The "Pixel Clk to Analog Out" section of Table 15, "AC Characteristics," is deleted, along with the associated figure "Analog Output Timing". In most modes the pixel clock is internal, so this number cannot be specified. Where a relationship can be established, such as DDOTCLK or SCLK (derivatives of the pixel clock) to DAC output, or LCLK (in VGA mode) to DAC output, no data is available.</p> <p>The DAC output slew rate in this section is specified elsewhere in the datasheet with discussion of the slew rate control.</p> <p>16. The section "External Circuitry Requirements" was deleted. A separate application note will have this information.</p> <p>17. Section 15.9, "Ordering Information," was added. This has a table of part numbers.</p>
5/09/94	<p>1. In Table 10, "Pin Descriptions," REFCLK only specified direct programming frequency range of 4 to 62 MHz. Added 2 to 100 MHz frequency range for M/N programming.</p> <p>2. Also in Table 10, "Pin Descriptions," noted that the DDOTCLK and SENSE outputs can be 3-stated under register control.</p> <p>3. Corrected some typos in Table 16, "Composite Video Output Waveform," and Table 17, "Composite Video Output Waveform,":</p> <ol style="list-style-type: none"> <li>Table 16, "Composite Video Output Waveform," Sync=NO, Pedestal=YES, changed white level voltage from 0.731 to 0.714.</li> <li>Table 16, "Composite Video Output Waveform," Sync=YES, Pedestal=YES, changed black level voltage from 0.356 to 0.339.</li> <li>Table 16, "Composite Video Output Waveform," Sync=YES, Pedestal=YES, changed blank level voltage from 0.285 to 0.286.</li> <li>Table 17, "Composite Video Output Waveform," Sync=YES, Pedestal=YES, changed blank level voltage from 0.285 to 0.286.</li> </ol> <p>4. Added Appendix A 1, "Switching Into VGA Mode."</p> <p>5. Added this 1.8.9, "Change Summary," section.</p>
7/20/94	<p>1. Corrected description of pixel PLL operation following a reset. Section 2.5, "PLL Setup and Reset," now indicates that the PLL will run at a frequency in the kilohertz range following a reset (or when it is "disabled"). The values of the PLL Control 2 register, and the PLL programming registers F0 - F15 are now shown to have reset values of 0x00. These values will cause the pixel frequency to be in the range of 1.25 KHz to 62.5 KHz following a reset.</p> <p>2. In section 2.6, "PLL Programming," a statement was removed that indicated a check for minimum VRF was unnecessary for M over N programming with an input reference above 4 MHz. This is not true.</p> <p>3. Section 3.3.4, "34 BPP," and "Pixel Format Register" description redefined stating that if 24 BPP Packed format is selected with the Pixel Format register, but the VRAM SIZE bit in the Miscellaneous Control 1 register is set for 32 bits, then the product operation is undefined.</p> <p>4. Cross references expanded to include section numbers with headings where applicable.</p> <p>5. Expanded the table of contents to include register description headings and page numbers.</p> <p>6. Fixed incorrect cross referenes.</p> <p>7. Miscellaneous typographical errors corrected.</p>



# Table of Contents

<b>Product Description</b> .....	<b>1</b>	4.4	Border Control .....	15
<b>Functional Block Diagram</b> .....	<b>1</b>	4.5	Sync Control .....	15
<b>Product Highlights</b> .....	<b>1</b>	4.6	Clocking and Pipeline Delay .....	16
<b>Applications</b> .....	<b>1</b>	4.6.1	Horizontal Sync .....	16
<b>1.0 Microprocessor Access</b> .....	<b>2</b>	4.6.2	Vertical Sync .....	16
1.1 VGA Access .....	2	4.6.3	Composite Sync .....	16
1.1.1 Palette .....	2	4.6.4	Horizontal Position Control .....	16
1.1.2 Palette Write .....	2	4.7	Additional Sync Control .....	16
1.1.3 Palette Read .....	3	4.8	24 Bit Packed Pixel Control .....	16
1.1.4 6/8 Bit Palette Access .....	3	<b>5.0 Cursor Operation</b> .....	<b>17</b>	
1.1.5 Palette Clocking .....	3	5.1	Cursor Enable .....	17
1.1.6 Palette Access Status .....	3	5.2	Cursor Array .....	17
1.1.7 Pixel Mask .....	4	5.2.1	Cursor Array Access .....	17
1.2 Indexed Access .....	4	5.2.2	Cursor Array Writes .....	17
1.2.1 Cursor Array .....	4	5.2.3	Cursor Array Reads .....	17
<b>2.0 Clocking</b> .....	<b>4</b>	5.3	Cursor Modes .....	18
2.1 PLL Inputs .....	4	5.4	Cursor Hot Spot .....	18
2.1.1 REFCLK .....	4	5.5	Cursor Position .....	18
2.1.2 EXTCLK .....	4	5.6	Interlace .....	18
2.2 PLL Outputs .....	4	5.7	Cursor Update and Display .....	19
2.2.1 SCLK .....	4	5.7.1	Position .....	19
2.2.2 DDOTCLK .....	5	5.7.2	Controls .....	19
2.3 Load Clock .....	5	5.7.3	Other .....	19
2.4 Pixel Clock (Dot Clock) .....	5	<b>6.0 DAC Control</b> .....	<b>20</b>	
2.5 PLL Setup and Reset .....	6	6.1	SOG - Composite Sync-On-Green .....	20
2.6 PLL Programming .....	6	6.2	BRB - Blank Red and Blue DACs .....	20
2.7 PLL Frequency Selection .....	7	6.3	DSR - DAC Slew Rate .....	20
2.8 Direct Programming .....	8	6.4	DPE - DAC Blanking Pedestal Enable ..	20
2.9 M/N Programming .....	9	<b>7.0 Power Management</b> .....	<b>20</b>	
2.10 General PLL Programming .....	9	7.1	DAC Power .....	20
2.11 Diagnostic Readback .....	9	7.2	Driver Power .....	20
<b>3.0 Modes of Operation</b> .....	<b>10</b>	7.3	Clocking Power .....	21
3.1 Bit Ordering .....	10	7.4	PLL Power .....	21
3.2 VGA Port .....	10	<b>8.0 Diagnostic Support</b> .....	<b>22</b>	
3.3 VRAM Pixel Port .....	10	8.1	Data Masks .....	22
3.3.1 4 BPP .....	10	8.2	MISR .....	22
3.3.2 8 BPP .....	10	8.3	DAC Comparators .....	22
3.3.3 16 BPP .....	11	<b>9.0 Internal Register - Summary</b> .....	<b>23</b>	
3.3.4 24 BPP .....	12	<b>10.0 Register Descriptions</b> .....	<b>25</b>	
3.3.5 32 BPP .....	12	10.1	Direct Access Registers .....	25
3.4 6 Bit Linear Palette Output .....	13		Palette Address (Write Mode) .....	25
3.5 Pixel Format Table .....	13		Palette Data.....	25
<b>4.0 Controls</b> .....	<b>15</b>		Pixel Mask.....	25
4.1 Blank and Border Control .....	15		Palette Address/Palette Access State....	26
4.2 Blanking Control .....	15		Index Low.....	26
4.3 Vertical Blanking .....	15		Index High .....	26

Indexed Data ..... 26  
 Index Control ..... 27  
 10.2 Indexed Registers ..... 27  
 10.2.1 Miscellaneous Control ..... 27  
     Miscellaneous Control 1 ..... 27  
     Miscellaneous Control 2 ..... 28  
     Miscellaneous Control 3 ..... 29  
     Miscellaneous Clock Control ..... 29  
     Sync Control ..... 30  
     Horizontal Sync Control ..... 30  
     Power Management ..... 31  
     DAC Operation ..... 31  
     Palette Control ..... 32  
 10.2.2 Pixel Representation ..... 32  
     Pixel Format ..... 32  
     8 Bit Pixel Control ..... 33  
     16 Bit Pixel Control ..... 33  
     24 Bit Packed Pixel Control ..... 34  
     32 Bit Pixel Control ..... 35  
 10.2.3 Frequency Selection ..... 36  
     PLL Control 1 ..... 36  
     PLL Control 2 ..... 37  
     Fixed PLL Reference Divider ..... 37  
     F0-F15: Frequency 0 to Frequency 15... 38  
     M0-M7, N0-N7 ..... 38  
 10.2.4 Cursor ..... 39  
     Cursor Control ..... 39  
     Cursor X Low ..... 40  
     Cursor X High ..... 40  
     Cursor Y Low ..... 41  
     Cursor Y High ..... 41  
     Cursor Hot Spot X ..... 42  
     Cursor Hot Spot Y ..... 42  
     Cursor Color 1 Red ..... 42  
     Cursor Color 1 Green ..... 42  
     Cursor Color 1 Blue ..... 42  
     Cursor Color 2 Red ..... 42  
     Cursor Color 2 Green ..... 42  
     Cursor Color 2 Blue ..... 43  
     Cursor Color 3 Red ..... 43  
     Cursor Color 3 Green ..... 43  
     Cursor Color 3 Blue ..... 43  
 10.2.5 Border Color ..... 43  
     Border Color Red ..... 43  
     Border Color Green ..... 43  
     Border Color Blue ..... 43  
 10.2.6 Diagnostic Support ..... 44  
     Revision Level ..... 44  
     ID ..... 44  
     DAC Sense ..... 44  
     MISR Red ..... 45  
     MISR Green ..... 45  
     MISR Blue ..... 45  
     PLL VCO Divider Input ..... 45

PLL Reference Divider Input ..... 45  
 VRAM Mask Low ..... 46  
 VRAM Mask High ..... 46

**11.0 Pin Descriptions ..... 47**  
**12.0 Electrical and Timing Specifications .... 53**  
**13.0 Video Waveforms ..... 56**  
**14.0 Package Information ..... 57**  
**15.0 Ordering Information ..... 57**  
**16.0 Change Summary ..... 58**

**Appendix**

**A.0 Anomalies ..... 60**  
 A.1 Switching Into VGA Mode ..... 60

**Table List**

Table 1. I/O Addresses ..... 2  
 Table 2. SCLK Frequencies ..... 5  
 Table 3. PLL Equations ..... 7  
 Table 4. PLL Control 1 EXT/INT Freq Sel ..... 8  
 Table 5. Direct Programming Ref Div Values ..... 8  
 Table 6. PLL Direct Programming Equations ..... 9  
 Table 7. Pixel Format Table ..... 14  
 Table 8. Cursor Modes ..... 19  
 Table 9. Internal Register Summary ..... 23  
 Table 10. Pin Descriptions ..... 47  
 Table 11. Signal List by Pin Number ..... 52  
 Table 12. Recommended Operating Conditions ... 53  
 Table 13. Absolute Maximum Ratings ..... 53  
 Table 14. DC Characteristics ..... 53  
 Table 15. AC Characteristics ..... 54  
 Table 16. Composite Video Output Waveform ..... 56  
 Table 17. Composite Video Output Waveform ..... 56  
 Table 18. Part Numbers ..... 57  
 Table 19. Summary of Changes ..... 58

**Figure List**

Figure 1. SCLK for 24 BPP Packed ..... 5  
 Figure 2. 24 BPP Packed Pixel Input (VRAM) ..... 12  
 Figure 3. Microprocessor Interface Timing ..... 55  
 Figure 4. Pixel Data/Video Ctrl Interface Timing.... 55  
 Figure 5. SCLK and LCLK Timing ..... 55